

OPERATION MANUAL

INDUSTRIAL ENGINE

TNV, TNM

3TNV74F

3TNV76F

3TNV80F

3TNV80FT

3TNV88F

3TNM74F

YANMAR

**California
Proposition 65 Warning**

Diesel engine exhaust and some of its constituents are known to the state of California to cause cancer, birth defects, and other reproductive harm.

Disclaimers:

All information, illustrations and specifications in this manual are based on the latest information available at the time of publishing. The illustrations used in this manual are intended as representative reference views only. Moreover, because of our continuous product improvement policy, we may modify information, illustrations and/or specifications to explain and/or exemplify a product, service or maintenance improvement. We reserve the right to make any change at any time without notice. YANMAR is a registered trademark of YANMAR POWER TECHNOLOGY CO., LTD. in Japan, the United States and/or other countries.

All Rights Reserved:

No part of this publication may be reproduced or used in any form by any means - graphic, electronic, or mechanical, including photocopying, recording, taping, or information storage and retrieval systems - without the written permission of YANMAR POWER TECHNOLOGY CO., LTD.

In case of exporting this product and providing the related technical material to non-residents in Japan or residents overseas, it is required to comply with the export and trade control laws and regulations of Japan and other relevant countries.
Please be sure to follow the necessary procedure.

OPERATION MANUAL	MODEL	3TNV74F, 3TNV76F, 3TNV80F, 3TNV80FT, 3TNV88F, 3TNM74F
	CODE	0ATN4-EN002C

INTRODUCTION

Welcome to the world of YANMAR Engines! YANMAR has been the leader in industrial diesel engines for over 90 years. We developed the world's first practical small-sized diesel engine in 1933. Our engineers are continuously developing new technology to keep YANMAR on the leading-edge of the industry. The TNM and TNV engines are only example of the new technology we have developed. We are committed to maintaining our environment, and are proud of our history of innovation, quality and respect for operator safety.

To help you enjoy your YANMAR TNM and TNV engines for many years to come, please follow these recommendations:

- Read and understand this Operation Manual before you operate the machine to ensure that you follow safe operating practices and maintenance procedures.
 - Keep this Operation Manual in a convenient place for easy access.
 - If this Operation Manual is lost or damaged, order a new one from your authorized YANMAR industrial engine dealer or distributor.
 - Make sure this manual is transferred to subsequent owners. This manual should be considered a permanent part of the engine and remain with it.
- Constant efforts are made to improve the quality and performance of YANMAR products, so some details included in this Operation Manual may differ slightly from your engine. If you have any questions about these differences, please contact your authorized YANMAR industrial engine dealer or distributor.
 - The specifications and components (instrument panel, fuel tank, etc.) described in this manual may differ from ones installed on your machine. Please refer to the manual provided by the manufacturer of these components.

INTRODUCTION

RECORD OF OWNERSHIP

Take a few moments to record the information you need when you contact YANMAR for service, parts or literature.

Engine model: _____

Engine serial No.: _____

Date purchased: _____

Dealer: _____

Dealer phone: _____

SYMBOL EXPLANATION

The following symbols are used throughout this manual to identify specific engine model information



This symbol indicates information pertaining to the following indirect injection engines:

- 3TNV74F
- 3TNV76F
- 3TNV80F
- 3TNV80FT
- 3TNM74F

All of the models conform to the engine emission regulations (EPA 2013 rules).



This symbol indicates information pertaining to the following direct injection engines:

- 3TNV88F

This model conform to the engine emission regulations (EPA 2013 rules).

TABLE OF CONTENTS

	Page
YANMAR WARRANTIES	7
YANMAR LIMITED WARRANTY	7
What is Covered by this Warranty?	7
How Long is the Warranty Period?	7
What the Engine Owner must Do:	8
To Locate an Authorized YANMAR Industrial Engine Dealer or Distributor:	8
What YANMAR will Do:	8
What is not Covered by this Warranty?	9
Warranty Limitations:	9
Warranty Modifications:	9
Questions:	9
EMISSION SYSTEM WARRANTY	10
Limited Emission Control System Warranty - USA Only.....	10
Limited Emission Control System Warranty - US EPA Certified Only	13
SAFETY	17
SAFETY STATEMENTS	17
SAFETY PRECAUTIONS	18
Before You Operate.....	18
During Operation and Maintenance.....	18

TABLE OF CONTENTS

PRODUCT OVERVIEW	29
YANMAR TNV ENGINE FEATURES AND APPLICATIONS	29
COMPONENT IDENTIFICATION	30
LOCATION OF LABELS	34
Engine Nameplate (Typical)	35
EMISSION CONTROL REGULATIONS	35
EPA/ARB Regulations - USA Only	35
EU Regulations	35
EMISSION CERTIFICATION LABELS	35
EPA/ARB Labels (Typical)	35
EU Labels (Typical)	35
ENGINE FAMILY	36
FUNCTION OF MAJOR ENGINE COMPONENTS.....	37
FUNCTION OF COOLING SYSTEM COMPONENTS.....	39
ELECTRONIC CONTROL SYSTEM.....	40
MAIN ELECTRONIC CONTROL COMPONENTS AND FEATURES	43
GAUGES AND INDICATORS	45
Gauges.....	45
Indicators.....	46
GAUGES AND INDICATORS OF ELECTRONIC CONTROL SYSTEM	47
Gauges.....	47
Indicators.....	47
CONTROLS	48
Key Switch.....	48
Glow Plugs	50
Governor Lever	50
Engine Stop Solenoid.....	50
Electronic Engine Speed Control	51
BEFORE YOU OPERATE	53
DIESEL FUEL	54
Diesel Fuel Specifications	54
Filling the Fuel Tank	57
Priming the Fuel System	58
ENGINE OIL.....	59
Engine Oil Specifications.....	59
Engine Oil Viscosity.....	59
Checking Engine Oil.....	60
Adding Engine Oil.....	60
Engine Oil Capacity (Typical)	61

ENGINE COOLANT	62
Engine Coolant Specifications.....	63
Filling Radiator with Engine Coolant.....	63
Daily Check of the Cooling System	64
Engine Coolant Capacity (Typical)	64
DAILY CHECKS	65
Visual Checks.....	65
Check Diesel Fuel, Engine Oil and Engine Coolant Levels.....	65
Check Engine Speed Control	65
Check Operator's Console	65
Check Indicators.....	65
ENGINE OPERATION	69
STARTING ENGINE	70
Cold start device for electronic controlled engines	71
High-Altitude Injection Control Device	72
CHECKING THE ENGINE DURING OPERATION	72
Adjust Engine Speed.....	74
SHUTTING DOWN THE ENGINE.....	74
PERIODIC MAINTENANCE	75
PRECAUTIONS	76
The Importance of Periodic Maintenance.....	76
Performing Periodic Maintenance	76
The Importance of Daily Checks	76
Keep a Log of Engine Hours and Daily Checks	76
YANMAR Replacement Parts.....	76
Tools Required	76
Ask Your Authorized YANMAR Industrial Engine Dealer or Distributor For Help	76
Required EPA/ARB Maintenance USA Only.....	77
EPA/ARB Installation Requirements USA Only.....	77
Tightening Fasteners.....	77
STANDARD TORQUE CHART	78
PERIODIC MAINTENANCE SCHEDULE	78
Periodic Maintenance Chart	78
PERIODIC MAINTENANCE PROCEDURES	80
After Initial 50 Hours of Operation	80
Every 50 Hours of Operation	82
Every 250 Hours of Operation	85
Every 500 Hours of Operation	91
Every 1000 Hours of Operation	97
Every 1500 Hours of Operation	98
Every 2000 Hours of Operation	99
Every 3000 Hours of Operation	101

TABLE OF CONTENTS

TROUBLESHOOTING	103
TROUBLESHOOTING CHART.....	104
TROUBLESHOOTING OF ELECTRONIC CONTROL SYSTEM....	106
Fault Detection Capability	106
SMARTASSIST-DIRECT	108
TROUBLESHOOTING INFORMATION.....	109
LIST OF POSSIBLE FAULTS OF ELECTRONIC CONTROLLED ENGINES	110
LONG-TERM STORAGE	113
BEFORE YOU PLACE THE ENGINE IN LONG-TERM STORAGE	114
RETURNING THE ENGINE TO SERVICE	115
SPECIFICATIONS	117
GENERAL	117
PRINCIPAL ENGINE SPECIFICATIONS	119

YANMAR WARRANTIES

YANMAR LIMITED WARRANTY

What is Covered by this Warranty?

YANMAR warrants to the original retail purchaser that a new YANMAR TNV series industrial engine will be free from defects in material and/or workmanship for the duration of the warranty period.

Note: YANMAR engines may be equipped with external components including, but not limited to: wiring harnesses, electrical devices, control panels, radiators, air filters, fuel filters, and/or exhaust systems that are supplied and/or installed by manufacturers other than YANMAR. For warranty information on such external components, please contact the machine or component manufacturer directly or see your authorized YANMAR dealer or distributor.

This warranty is provided in lieu of all other warranties, express or implied. YANMAR specifically disclaims any implied warranties of merchantability or fitness for a particular purpose, except where such disclaimer is prohibited by law. If such disclaimer is prohibited by law, then implied warranties shall be limited in duration to the life of the express warranty.

How Long is the Warranty Period?

The YANMAR standard limited warranty period runs for a period of **twenty-four (24) months or two-thousand (2000) engine operation hours**, whichever occurs first. An extended limited warranty of thirty-six (36) months or three thousand (3000) engine operating hours, whichever occurs first, is provided for these specific parts only: the cylinder block, cylinder head, crankshaft forging, connecting rods, flywheel, flywheel housing, camshaft, timing gear, and gear case. The warranty period for both the standard limited warranty and the extended limited warranty (by duration or operation hours) begins on the date of delivery to the original retail purchaser and is valid only until the applicable warranted duration has passed or the operation hours are exceeded, whichever comes first.

YANMAR WARRANTIES

What the Engine Owner must Do:

If you believe your YANMAR engine has experienced a failure due to a defect in material and/or workmanship, you must contact an authorized YANMAR industrial engine dealer or distributor within thirty (30) days of discovering the failure. You must provide proof of ownership of the engine, proof of the date of the engine purchase and delivery, and documentation of the engine operation hours. Acceptable forms of proof of delivery date include, but are not limited to: the original warranty registration or sales receipts or other documents maintained in the ordinary course of business by YANMAR dealers and/or distributors, indicating the date of delivery of the YANMAR product to the original retail purchaser. This information is necessary to establish whether the YANMAR product is still within the warranty period. Thus, YANMAR strongly recommends you register your engine as soon as possible after purchase in order to facilitate any future warranty matters.

You are responsible for the transportation of the engine to and from the repair location as designated by YANMAR.

To Locate an Authorized YANMAR Industrial Engine Dealer or Distributor:

You can locate your nearest authorized YANMAR industrial engine dealer or distributor by visiting the YANMAR website at:

<https://www.yanmar.com/global/> (The English language page will be displayed.)

- “Click” on “Dealer Locator” in the website heading to view the “Dealer Locator” menu.
- Choose the Country from the pull down menu.
- Choose the Product Category from the pull down menu.
- “Click” on “Search” to browse YANMAR dealer or distributor.

You may also contact YANMAR by clicking on “Contact” icon in the website heading and typing in your question or comment.

What YANMAR will Do:

YANMAR warrants to the original retail purchaser of a new YANMAR engine that YANMAR will make such repairs and/or replacements at YANMAR’s option, of any part(s) of the YANMAR product covered by this warranty found to be defective in material and/or workmanship. Such repairs and/or replacements will be made at a location designated by YANMAR at no cost to the purchaser for parts or labor.

What is not Covered by this Warranty?

This warranty does not cover parts affected by or damaged by any reason other than defective materials or workmanship, including, but not limited to, accident, misuse, abuse, "Acts of God," neglect, improper installation, improper maintenance, improper storage, the use of unsuitable attachments or parts, the use of contaminated fuels, the use of fuels, oils, lubricants, or fluids other than those recommended in your YANMAR Operation Manual, unauthorized alterations or modifications, ordinary wear and tear, and rust or corrosion. This warranty does not cover the cost of parts and/or labor required to perform normal/scheduled maintenance on your YANMAR engine. This warranty does not cover consumable parts such as, but not limited to, filters, belts, hoses, fuel injector nozzles, lubricants and cleaning fluids. This warranty does not cover the cost of shipping the product to or from the warranty repair facility.

Warranty Limitations:

The foregoing is YANMAR's only obligation to you and your exclusive remedy for breach of warranty. Failure to follow the requirements for submitting a claim under this warranty may result in a waiver of all claims for damages and other relief. **In no event shall YANMAR or any authorized industrial engine dealer or distributor be liable for incidental, special or consequential damages.** Such consequential damages may include, but not be limited to, loss of revenue, loan payments, cost of rental of substitute equipment, insurance coverage, storage, lodging, transportation, fuel, mileage, and telephone costs. The limitations in this warranty apply regardless of whether your claims are based on breach of contract, tort (including negligence and strict liability) or any other theory. Any action arising hereunder must be brought within one (1) year after the cause of action accrues or it shall be barred. Some states and countries do not allow certain limitations on warranties or for breach of warranties. **This warranty gives you specific legal rights, and you may also have other rights which vary from state to state and country to country.** Limitations set forth in this paragraph shall not apply to the extent that they are prohibited by law.

Warranty Modifications:

Except as modified in writing and signed by the parties, this warranty is and shall remain the complete and exclusive agreement between the parties with respect to warranties, superseding all prior agreements, written and oral, and all other communications between the parties relating to warranties. **No person or entity is authorized to give any other warranty or to assume any other obligation on behalf of YANMAR, either orally or in writing.**

Questions:

If you have any questions or concerns regarding this warranty, please call or write to the nearest authorized YANMAR industrial engine dealer or distributor or other authorized facility.

EMISSION SYSTEM WARRANTY

Limited Emission Control System Warranty - USA Only

■ Your warranty rights and obligations:

The California Air Resources Board (CARB), the United States Environmental Protection Agency (EPA) and YANMAR POWER TECHNOLOGY CO., LTD. hereafter referred to as YANMAR, are pleased to explain the emission control system warranty on your 2026, 2027, or 2028 model year compression-ignition engine. In California, new heavy-duty off-road engines must be designed, built and equipped to meet the State’s stringent anti-smog standards. In the remaining forty nine (49) states, new non-road compression-ignition engines must be designed, built and equipped to meet the United States EPA emissions standards. YANMAR must warrant the emission control system on your engine for the periods of time listed below provided there has been no abuse, neglect or improper maintenance of your engine.

Your emission control system may include parts such as the fuel injection system, the air induction system, the electronic control system, EGR (Exhaust Gas Recirculation) system and the exhaust gas after treatment (diesel particulate filter system, urea SCR system). Also included may be hoses, belts, connectors and other emission-related assemblies.

Where a warrantable condition exists, YANMAR will repair your heavy-duty off-road compression-ignition engine at no cost to you including diagnosis, parts and labor.

■ Manufacturer’s warranty coverage:

2026, 2027, or 2028 model year heavy-duty off-road compression-ignition engines are warranted for the periods listed below. If any emission-related part on your engine is defective, the part will be repaired or replaced by YANMAR.

If your engine is certified as	And its maximum power is	And its rated speed is	Then its warranty period is
Variable speed or constant speed	$kW < 8$	Any speed	2,000 hours or two (2) years whichever comes first. In the absence of a device to measure the hours of use, the engine has a warranty period of two (2) years.
Variable speed or constant speed	$8 \leq kW < 19$	Any speed	2,000 hours or two (2) years whichever comes first. In the absence of a device to measure the hours of use, the engine has a warranty period of two (2) years.
Constant speed	$19 \leq kW < 37$	3,000 rpm or higher	2,000 hours or two (2) years whichever comes first. In the absence of a device to measure the hours of use, the engine has a warranty period of two (2) years.
Constant speed	$19 \leq kW < 37$	Less than 3,000 rpm	3,000 hours or five (5) years whichever comes first. In the absence of a device to measure the hours of use, the engine has a warranty period of five (5) years.
Variable speed	$19 \leq kW < 37$	Any speed	3,000 hours or five (5) years whichever comes first. In the absence of a device to measure the hours of use, the engine has a warranty period of five (5) years.
Variable speed or constant speed	$kW \geq 37$	Any speed	3,000 hours or five (5) years whichever comes first. In the absence of a device to measure the hours of use, the engine has a warranty period of five (5) years.

■ Warranty coverage:

This warranty is transferable to each subsequent purchaser for the duration of the warranty period. YANMAR recommends that repair or replacement of any warranted part will be performed at an authorized YANMAR dealer.

Warranted parts not scheduled for replacement as required maintenance in the owner's manual shall be warranted for the warranty period. Warranted parts scheduled for replacement as required maintenance in the owner's manual are warranted for the period of time prior to the first scheduled replacement.

Any warranted parts scheduled for replacement as required maintenance that are repaired or replaced under warranty shall be warranted for the remaining period of time prior to the first scheduled replacement. Any part not scheduled for replacement that is repaired or replaced under warranty shall be warranted for the remaining warranty period.

During the warranty period, YANMAR is liable for damages to other engine components caused by the failure of any warranted part during the warranty period.

Any replacement part which is functionally identical to the original equipment part in all respects may be used in the maintenance or repair of your engine and shall not reduce YANMAR's warranty obligations. Add-on or modified parts that are not exempted may not be used. The use of any non-exempted add-on or modified parts shall be grounds for disallowing a warranty.

■ Warranted parts:

This warranty covers engine components that are a part of the emission control system of the engine as delivered by YANMAR to the original retail purchaser. Such components may include the following:

- Fuel injection system (including Altitude compensation system)
- Cold start enrichment system
- Intake manifold and Air intake throttle valve
- Turbocharger systems
- Exhaust manifold and exhaust throttle valve
- Positive crankcase ventilation system
- Charge Air Cooling systems
- Exhaust Gas Recirculation (EGR) systems
- Exhaust gas after treatment (Diesel Particulate Filter (DPF) system, urea SCR system)
- Electronic Control units, sensors, solenoids and wiring harnesses used in above systems
- Hoses, belts, connectors and assemblies used in above systems
- Emission Control Information Labels

Since emissions related parts may vary slightly between models, certain models may not contain all of these parts and other models may contain the functional equivalents.

YANMAR WARRANTIES

■ Exclusions:

Failures other than those arising from defects in material or workmanship are not covered by this warranty. The warranty does not extend to the following: malfunctions caused by abuse, misuse, improper adjustment, modification, alteration, tampering, disconnection, improper or inadequate maintenance, or use of non-recommended fuels and lubricating oils; accident-caused damage and replacement of expendable items made in connection with scheduled maintenance. YANMAR disclaims any responsibility for incidental or consequential such as loss of time, inconvenience, loss of use of equipment/engine or commercial loss.

■ Owner's warranty responsibilities:

As the off-road compression-ignition engine owner, you are responsible for the performance of the required maintenance listed in your owner's manual. YANMAR recommends that you retain all receipts, covering maintenance on your off-road compression-ignition engine, but YANMAR cannot deny warranty solely for the lack of receipts or for your failure to ensure the performance of all scheduled maintenance.

As the off-road engine owner, you should however be aware that YANMAR may deny your warranty coverage if your off-road compression-ignition engine or a part has failed due to abuse, neglect, improper maintenance or unapproved modifications.

Your engine is designed to operate on diesel fuel only. Use of any other fuel may result in your engine no longer operating in compliance with California's and EPA's emissions requirements.

You are responsible for initiating the warranty process. The ARB and EPA suggest that you present your off-road engine to a YANMAR dealer as soon as a problem exists. The warranty repairs should be completed by the dealer as expeditiously as possible. If you have any questions regarding your warranty rights and responsibilities, you should contact YANMAR America Corporation. If you would like to find the nearest YANMAR dealer or authorized service center, you should contact YANMAR America Corporation.

Website: <https://www.yanmar.com>

E-mail: CS_support@yanmar.com

Toll free telephone number: 1-800-872-2867, 1-855-416-7091

■ What the emergency stationary type engine owner must do:

The engines for emergency stationary type generators certified by Federal Law (40 CFR Part 60) are limited to emergency use only, and the operation for maintenance checks and verification test for functions is required. The total operating hours for maintenance and verification test for functions should not exceed 100 hours per year. However, there is no limitation on the operating hours for emergency use. Keep a log of the number of hours the engine is operated for both emergency use and non-emergency use. Also, note the reason for the operation.

Limited Emission Control System Warranty - US EPA Certified Only

■ Your warranty rights and obligations:

The United States Environmental Protection Agency (EPA) and YANMAR POWER TECHNOLOGY CO., LTD. hereafter referred to as YANMAR, are pleased to explain the emission control system warranty on your 2024 model year and later compression-ignition engine. New non-road compression-ignition engines must be designed, built and equipped to meet the United States EPA emissions standards. YANMAR must warrant the emission control system on your engine for the periods of time listed below provided there has been no abuse, neglect or improper maintenance of your engine.

Your emission control system may include parts such as the fuel injection system, the air induction system, the electronic control system, EGR (Exhaust Gas Recirculation) system and the exhaust gas after treatment (diesel particulate filter system, urea SCR system). Also included may be hoses, belts, connectors and other emission-related assemblies.

Where a warrantable condition exists, YANMAR will repair your non-road compression-ignition engine at no cost to you including diagnosis, parts and labor.

■ Manufacturer’s warranty coverage:

Non-road compression-ignition engines are warranted for the periods listed below. If any emission-related part on your engine is defective, the part will be repaired or replaced by YANMAR.

If your engine is certified as	And its maximum power is	And its rated speed is	Then its warranty period is
Variable speed or constant speed	kW < 8	Any speed	2,000 hours or two (2) years whichever comes first. In the absence of a device to measure the hours of use, the engine has a warranty period of two (2) years.
Variable speed or constant speed	8 ≤ kW < 19	Any speed	2,000 hours or two (2) years whichever comes first. In the absence of a device to measure the hours of use, the engine has a warranty period of two (2) years.
Constant speed	19 ≤ kW < 37	3,000 rpm or higher	2,000 hours or two (2) years whichever comes first. In the absence of a device to measure the hours of use, the engine has a warranty period of two (2) years.
Constant speed	19 ≤ kW < 37	Less than 3,000 rpm	3,000 hours or five (5) years whichever comes first. In the absence of a device to measure the hours of use, the engine has a warranty period of five (5) years.
Variable speed	19 ≤ kW < 37	Any speed	3,000 hours or five (5) years whichever comes first. In the absence of a device to measure the hours of use, the engine has a warranty period of five (5) years.
Variable speed or constant speed	kW ≥ 37	Any speed	3,000 hours or five (5) years whichever comes first. In the absence of a device to measure the hours of use, the engine has a warranty period of five (5) years.

YANMAR WARRANTIES

■ Warranty coverage:

This warranty is transferable to each subsequent purchaser for the duration of the warranty period. YANMAR recommends that repair or replacement of any warranted part will be performed at an authorized YANMAR dealer.

Warranted parts not scheduled for replacement as required maintenance in the owner's manual shall be warranted for the warranty period. Warranted parts scheduled for replacement as required maintenance in the owner's manual are warranted for the period of time prior to the first scheduled replacement.

Any warranted parts scheduled for replacement as required maintenance that are repaired or replaced under warranty shall be warranted for the remaining period of time prior to the first scheduled replacement. Any part not scheduled for replacement that is repaired or replaced under warranty shall be warranted for the remaining warranty period.

During the warranty period, YANMAR is liable for damages to other engine components caused by the failure of any warranted part during the warranty period.

Any replacement part which is functionally identical to the original equipment part in all respects may be used in the maintenance or repair of your engine and shall not reduce YANMAR's warranty obligations. Add-on or modified parts that are not exempted may not be used. The use of any non-exempted add-on or modified parts shall be grounds for disallowing a warranty.

■ Warranted parts:

This warranty covers engine components that are a part of the emission control system of the engine as delivered by YANMAR to the original retail purchaser. Such components may include the following:

- Fuel injection system (including Altitude compensation system)
- Cold start enrichment system
- Intake manifold and Air intake throttle valve
- Turbocharger systems
- Exhaust manifold and exhaust throttle valve
- Positive crankcase ventilation system
- Charge Air Cooling systems
- Exhaust Gas Recirculation (EGR) systems
- Exhaust gas after treatment (Diesel Particulate Filter (DPF) system, urea SCR system)
- Electronic Control units, sensors, solenoids and wiring harnesses used in above systems
- Hoses, belts, connectors and assemblies used in above systems
- Emission Control Information Labels

Since emissions related parts may vary slightly between models, certain models may not contain all of these parts and other models may contain the functional equivalents.

■ Exclusions:

Failures other than those arising from defects in material or workmanship are not covered by this warranty. The warranty does not extend to the following: malfunctions caused by abuse, misuse, improper adjustment, modification, alteration, tampering, disconnection, improper or inadequate maintenance, or use of non-recommended fuels and lubricating oils; accident-caused damage and replacement of expendable items made in connection with scheduled maintenance. YANMAR disclaims any responsibility for incidental or consequential such as loss of time, inconvenience, loss of use of equipment/engine or commercial loss.

■ Owner's warranty responsibilities:

As the non-road compression-ignition engine owner, you are responsible for the performance of the required maintenance listed in your owner's manual. YANMAR recommends that you retain all receipts, covering maintenance on your non-road compression-ignition engine, but YANMAR cannot deny warranty solely for the lack of receipts or for your failure to ensure the performance of all scheduled maintenance.

As the non-road engine owner, you should however be aware that YANMAR may deny your warranty coverage if your non-road compression-ignition engine or a part has failed due to abuse, neglect, improper maintenance or unapproved modifications.

Your engine is designed to operate on diesel fuel only. Use of any other fuel may result in your engine no longer operating in compliance with EPA's emissions requirements.

You are responsible for initiating the warranty process. The EPA suggests that you present your non-road engine to a YANMAR dealer as soon as a problem exists. The warranty repairs should be completed by the dealer as expeditiously as possible. If you have any questions regarding your warranty rights and responsibilities, you should contact YANMAR America Corporation. If you would like to find the nearest YANMAR dealer or authorized service center, you should contact YANMAR America Corporation.

Website: <https://www.yanmar.com>

E-mail: CS_support@yanmar.com

Toll free telephone number: 1-800-872-2867, 1-855-416-7091

■ What the emergency stationary type engine owner must do:

The engines for emergency stationary type generators certified by Federal Law (40 CFR Part 60) are limited to emergency use only, and the operation for maintenance checks and verification test for functions is required. The total operating hours for maintenance and verification test for functions should not exceed 100 hours per year. However, there is no limitation on the operating hours for emergency use. Keep a log of the number of hours the engine is operated for both emergency use and non-emergency use. Also, note the reason for the operation.

This Page Intentionally Left Blank

SAFETY

SAFETY STATEMENTS

YANMAR is concerned for your safety and your machine's condition. Safety statements are one of the primary ways to call your attention to the potential hazards associated with YANMAR TNM and TNV engines operation. Follow the precautions listed throughout the manual before operation, during operation and during periodic maintenance procedures for your safety, the safety of others and to protect the performance of your engine. Keep the labels from becoming dirty or torn and replace them if they are lost or damaged. Also, if you need to replace a part that has a label attached to it, make sure you order the new part and label at the same time.



This safety alert symbol appears with most safety statements. It means attention, become alert, your safety is involved! Please read and abide by the message that follows the safety alert symbol.

DANGER

DANGER indicates a hazardous situation which, if not avoided, *will* result in death or serious injury.

WARNING

WARNING indicates a hazardous situation which, if not avoided, *could* result in death or serious injury.

CAUTION

CAUTION indicates a hazardous situation which, if not avoided, *could* result in minor or moderate injury.

NOTICE

NOTICE indicates a situation which can cause damage to the machine, personal property and/or the environment or cause the equipment to operate improperly.

SAFETY PRECAUTIONS

Before You Operate

NOTICE



- Never permit anyone to operate the engine or driven machine without proper training.

- Read and understand this Operation Manual before you operate or service the machine to ensure that you follow safe operating practices and maintenance procedures.
- Machine safety signs and labels are additional reminders for safe operating and maintenance techniques.
- See your authorized YANMAR industrial engine dealer or distributor for additional training.

During Operation and Maintenance

⚠ DANGER

Scald Hazard!



- **Never remove the radiator cap if the engine is hot. Steam and hot engine coolant will spurt out and seriously burn you. Allow the engine to cool down before you attempt to remove the radiator cap.**
- **Tighten the radiator cap securely after you check the radiator. Steam can spurt out during engine operation if the cap is loose.**
- **Always check the level of the engine coolant by observing the reserve tank.**
- **Failure to comply will result in death or serious injury.**

⚠ DANGER

Explosion Hazard!



- **Keep the area around the battery well-ventilated. While the engine is running or the battery is charging, hydrogen gas is produced which can be easily ignited.**
- **Keep sparks, open flame and any other form of ignition away while the engine is running or battery is charging.**
- **Never short out the battery terminals, including when checking the remaining battery charge. This will result in a spark and may cause an explosion or fire. Use a hydrometer to check the remaining battery charge.**
- **If the electrolyte is frozen, slowly warm the battery before you recharge it.**
- **Failure to comply will result in death or serious injury.**

Sudden Movement Hazard!



- **Never start the engine by shorting out the starter terminal and the battery terminal (Jump-start). The machine may move suddenly if the machine safety circuit is released, but the gear is still engaged.**
- **Failure to comply will result in death or serious injury.**

⚠ DANGER**Fire and Explosion Hazard!**

- Diesel fuel is extremely flammable and explosive under certain conditions.

- When you remove any fuel system component to perform maintenance (such as changing the fuel filter) place an approved container under the opening to catch the fuel.
- Never use a shop rag to catch the fuel. Vapors from the rag are flammable and explosive.
- Wipe up any spills immediately.
- Wear eye protection. The fuel system is under pressure and fuel could spray out when you remove any fuel system component.
- Only use the key switch to start the engine.
- Never jump-start the engine. Sparks caused by shorting the battery to the starter terminals may cause a fire or explosion.
- Only fill the fuel tank with diesel fuel. Filling the fuel tank with gasoline may result in a fire and will damage the engine.
- Never refuel with the engine running.
- Keep sparks, open flames or any other form of ignition (match, cigarette, static electric source) well away when refueling.
- Never overfill the fuel tank.
- Fill the fuel tank. Store any containers containing fuel in a well-ventilated area, away from any combustibles or sources of ignition.
- Be sure to place the diesel fuel container on the ground when transferring the diesel fuel from the pump to the container. Hold the hose nozzle firmly against the side of the container while filling it. This prevents static electricity buildup which could cause sparks and ignite fuel vapors.

⚠ DANGER

(Continued)

- Never place diesel fuel or other flammable material such as oil, hay or dried grass close to the engine during engine operation or shortly after shutdown.
- Before you operate the engine, check for fuel leaks. Replace rubberized fuel hoses every two years or every 2000 hours of engine operation, whichever comes first, even if the engine has been out of service. Rubberized fuel lines tend to dry out and become brittle after two years or 2000 hours of engine operation, whichever comes first.
- Never remove the fuel cap with the engine running.
- Never use diesel fuel as a cleaning agent.
- Failure to comply will result in death or serious injury.

Crush Hazard!

- When you need to transport an engine for repair, have a helper assist you to attach it to a hoist and load it on a truck.
- Never stand under a hoisted engine. If the hoist mechanism fails, the engine will fall on you, causing death or serious injury.
- Failure to comply will result in death or serious injury.

WARNING

Sever Hazard!



- Keep hands and other body parts away from moving/rotating parts such as the cooling fan, flywheel or PTO shaft.

- Wear tight-fitting clothing and keep your hair short or tie it back while the engine is running.
- Remove all jewelry before you operate or service the machine.
- Never start the engine in gear. Sudden movement of the engine and/or machine could cause death or serious personal injury.
- Never operate the engine without the guards in place.
- Before you start the engine make sure that all bystanders are clear of the area.
- Keep children and pets away while the engine is operating.
- Check before starting the engine that any tools or shop rags used during maintenance have been removed from the area.
- Failure to comply could result in death or serious injury.

Exhaust Hazard!



- Never operate the engine in an enclosed area such as a garage, tunnel, underground room, manhole or ship's hold without proper ventilation.
- Never block windows, vents, or other means of ventilation if the engine is operating in an enclosed area. All internal combustion engines create carbon monoxide gas during operation. Accumulation of this gas within an enclosure could cause illness or even death.
- Make sure that all connections are tightened to specifications after repair is made to the exhaust system.
- Failure to comply could result in death or serious injury.

WARNING

Alcohol and Drug Hazard!



- Never operate the engine while you are under the influence of alcohol or drugs.

- Never operate the engine when you are feeling ill.
- Failure to comply could result in death or serious injury.

Exposure Hazard!



- Wear personal protective equipment such as gloves, work shoes, eye and hearing protection as required by the task at hand.
- Never wear jewelry, unbuttoned cuffs, ties or loose-fitting clothing when you are working near moving/rotating parts such as the cooling fan, flywheel or PTO shaft.
- Always tie back long hair when you are working near moving/rotating parts such as a cooling fan, flywheel, or PTO shaft.
- Never operate the engine while wearing a headset to listen to music or radio because it will be difficult to hear the alert signals.
- Failure to comply could result in death or serious injury.

⚠ WARNING**Burn Hazard!**

- If you drain the engine lubricating oil while it is still hot, stay clear of the hot engine lubricating oil to avoid being burned. Always wear eye protection when you handle the engine coolant.
- If you must drain the engine coolant while it is still hot, stay clear of the hot engine coolant to avoid being burned.
- Keep your hands and other body parts away from hot engine surfaces such as the muffler, exhaust pipe, turbocharger (if equipped) and engine block during operation and shortly after you shut the engine down. These surfaces are extremely hot while the engine is operating and could seriously burn you.
- Failure to comply could result in death or serious injury.

Burn Hazard!

- Batteries contain sulfuric acid. Never allow battery fluid to come in contact with clothing, skin or eyes. Severe burns could result. Always wear safety goggles and protective clothing when servicing the battery. If battery fluid contacts the eyes and/or skin, immediately flush the affected area with a large amount of clean water and obtain prompt medical treatment.
- Failure to comply could result in death or serious injury.

⚠ WARNING**High-Pressure Hazard!**

- While the engine is running or right after the engine has stopped, there is still high-pressure fuel left in the fuel piping system. When you need to disassemble the fuel system, wait for 10 to 15 minutes after stopping the engine.
- If fuel is spraying out or leaking from broken fuel system such as high-pressure fuel injection lines, it may be in high-pressure. Avoid skin contact. High-pressure fuel can penetrate your skin and result in serious injury. If you are exposed to high-pressure fuel spray, obtain prompt medical treatment.
- Disassembling or repairing the fuel system shall be done by professionals such as the authorized YANMAR distributor or dealer.
- Failure to comply could result in death or serious injury.

Shock Hazard!

- Turn off the battery switch (if equipped) or disconnect the negative battery cable before servicing the electrical system.
- Check the electrical harnesses for cracks, abrasions, and damaged or corroded connectors. Always keep the connectors and terminals clean.
- Failure to comply could result in death or serious injury.

WARNING

Entanglement Hazard!



- Stop the engine before you begin to service it.

- Never leave the key in the key switch when you are servicing the engine. Someone may accidentally start the engine and not realize you are servicing it. This could result in a serious injury.
- If you must service the engine while it is operating, remove all jewelry, tie back long hair, and keep your hands, other body parts and clothing away from moving/rotating parts.
- Failure to comply could result in death or serious injury.

Sudden Movement Hazard!

- Before engaging the transmission or PTO, warm up the engine for at least 5 minutes and then set the speed back to normal. Engaging the transmission or PTO at an elevated engine speed could result in unexpected movement of the equipment.
- Failure to comply could result in death or serious injury.

WARNING

Precaution regarding the ECU (Engine Controller) of Electronic Controlled Engine

- Never use the ECU for purposes that are not intended by YANMAR; such as using unauthorized ECU, writing unauthorized data to ECU, leaving it broken, or removing sensors and actuators. Doing so could result in the violation of emission control regulations and will void the product warranty.
- Be sure to use the ECU in conjunction with the engines whose models or serial numbers are specified by YANMAR. Other ECU/engine combinations than specified will void the engine warranty.
- Replacing the fuel injection pump involves rewriting the fuel injection data in the ECU. Be sure to contact your local YANMAR dealer before replacing the fuel injection pump. Failure to rewrite the fuel injection data before replacing the fuel injection pump will void the engine warranty.
- Replacing the ECU involves migrating the fuel injection data to the existing ECU to the new unit. Be sure to contact your local YANMAR dealer before replacing the ECU. Failure to migrate the fuel injection data before replacing the ECU will void the engine warranty.
- Improper use or misuse of the ECU may result in death or serious injury due to an abrupt and unexpected increase in engine speed.

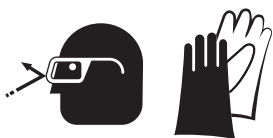
CAUTION**Engine Coolant Hazard!**

- **Wear eye protection and rubber gloves when you handle long life or extended life engine coolant. If contact with the eyes or skin should occur, flush eyes and wash immediately with clean water.**
- **Failure to comply may result in minor or moderate injury.**

Flying Object Hazard!

- **Always wear eye protection when servicing the engine and when using compressed air or high-pressure water. Dust, flying debris, compressed air, pressurized water or steam may injure your eyes.**
- **Failure to comply may result in minor or moderate injury.**
- **When using a 120 V system only, push the change-over switch to the right (120 V).**
- **The main switch should always be kept in the ON position during operation.**
- **Before starting the engine, always turn the switches on the working instruments (lighting apparatus, motor, etc.) to their OFF position. If the switches are not OFF, the sudden application of load when the engine is started could be very dangerous.**

NOTICE**Diesel Fuel**

- **Poor quality fuel can reduce engine performance and cause damage. Only use diesel fuels recommended by YANMAR for the best engine performance. The recommended fuel complies with the U.S. EPA and ARB protection guidelines.**
- **Only use clean diesel fuel.**
- **Keep the fuel tank and fuel-handling equipment clean at all times. Be careful not to let any contaminants or even dust from the outside into the filler port when supplying fuel.**
- **Never remove the primary strainer (if equipped) from the fuel tank filler port. If removed, dirt and debris could get into the fuel system causing it to clog.**
- **Be sure to use YANMAR genuine filter for replacing the fuel filter or the water separator filter.**

Engine Lubricating Oil

- **Only use the engine lubricating oil specified. Other oils may affect warranty coverage, cause internal engine components to seize and/or shorten engine life.**
- **Prevent dirt and debris from contaminating the engine lubricating oil. Carefully clean the oil cap/dipstick and the surrounding area before you remove the cap.**
- **Never mix different types of engine lubricating oil. This may adversely affect the lubricating properties of the engine oil.**
- **Always keep the oil level between the upper and lower lines on the oil cap/dipstick.**
- **Never overfill the engine with engine lubricating oil. Overfilling may result in white exhaust smoke, engine overspeed or internal damage.**
- **Be sure to use YANMAR genuine filter for replacing the engine lubricating oil filter.**

NOTICE

Engine Coolant

- Only use the engine coolant specified. Other engine coolants may affect warranty coverage, cause an internal buildup of rust and scale and/or shorten engine life.
- Prevent dirt and debris from contaminating the engine coolant. Carefully clean the radiator cap and the surrounding area before you remove the cap.
- Never mix different types of engine coolants. This may adversely affect the properties of the engine coolant.

Inspecting and Starting

- If any problem is noted during the visual check, the necessary corrective action should be taken before you operate the engine.
- If the unit has an electric fuel pump, in the case of DI engine, since air is automatically bled, by keeping the key of the starter switch in the ON position for 10 to 15 seconds, the fuel system can be primed. If this is an IDI engine, keep the key in the ON position (within 15 seconds) until fuel without bubbles comes out from the air bleeding bolt. Here, do not turn the key to the START position.
- If the unit has a mechanical fuel pump, when you prime the fuel system, operate the fuel priming lever of the mechanical fuel pump several times until the fuel filter cup is filled with fuel. On top of that, operate the fuel feed pump for several times until fuel without bubbles comes out from the air bleeding bolt.

If any indicator fails to illuminate when the key switch is in the ON position, see your authorized YANMAR industrial engine dealer or distributor for service before operating the engine.

Never hold the key in the START position for longer than 15 seconds.
Take a pause of at least 30 seconds until the restart. The starter motor may overheat and cause damage.

If the engine fails to start:
Wait until the engine comes to a complete stop before you attempt to start it again. Engaging the starter while the engine is still rotating will result in damage to the starter and flywheel.

NOTICE

Never use an engine starting aid such as ether. Engine damage will result.

Never engage the starter motor while the engine is running. This may damage the starter motor pinion and/or ring gear.

Engine Break-in Period

New engine break-in:

- On the initial engine start-up, allow the engine to idle for approximately 15 minutes while you check for proper engine lubricating oil pressure, diesel fuel leaks, engine lubricating oil leaks, coolant leaks, and for proper operation of the indicators and/or gauges.
- During the first hour of operation, vary the engine speed and the load on the engine. Short periods of maximum engine speed and load are desirable. Avoid prolonged operation at minimum or maximum engine speeds and loads for the next four to five hours.
- During the break-in period, carefully observe the engine lubricating oil pressure and engine coolant temperature.
- During the break-in period, check the engine lubricating oil and coolant levels frequently.

Make sure the engine is installed on a level surface. If a continuously running engine is installed at an angle greater than (30°) in any direction or if an engine runs for short periods of time (less than three minutes) at an angle greater than (35°) in any direction, engine lubricating oil may enter the combustion chamber causing excessive engine speed and white exhaust smoke. This may cause serious engine damage.

Alarm System

If there is a problem with the engine and/or its control components, the engine failure lamp comes on and indicates the status. If the engine failure lamp illuminates during engine operation, stop the engine immediately. Do not keep running the engine while the engine failure lamp is on. It will not only void the engine warranty, but could result in a serious malfunction of or damage to the engine. Determine the cause and repair the problem before you continue to operate the engine.

NOTICE

The illustrations and descriptions of optional equipment in this manual, such as the operator's console, are for a typical engine installation. Refer to the documentation supplied by the optional equipment manufacturer for specific operation and maintenance instructions.

Environment Conditions for Operation

Observe the following environmental operating conditions to maintain engine performance and avoid premature engine wear:

- Avoid operating in extremely dusty conditions.
- Avoid operating in the presence of chemical gases or fumes.
- Avoid operating in a corrosive atmosphere such as salt water spray.
- Never expose the engine to the rain.
- If the ambient temperature exceeds +45 °C (+113 °F) or falls below -15 °C (+5 °F), there are possibilities of:
 - If the ambient temperature exceeds +45 °C (+113 °F), engine lubricating oil degrades due to the overheating of the engine.
 - If the ambient temperature falls below -15 °C (+5 °F), parts degrade and shortens its life due to the hardening of the rubber parts.

Contact your authorized YANMAR dealer or distributor when using in such temperature range.

- Further, for engines with turbochargers, be aware that leaving them idling or working in low load in an environment with ambient temperature below -15 °C (+5 °F) may freeze the intake pipe. If this continues, load-operate the engine every three hours to prevent freezing.
- Contact your authorized YANMAR industrial engine dealer or distributor if the engine will be operated at high altitude. High altitude reduces engine power, de-stabilizes operation and generates exhaust gas that exceeds the specification amount in design.

NOTICE

- When the engine is operated in dusty conditions, clean the air cleaner element more frequently.
- Never operate the engine with the air cleaner element(s) removed. This may allow foreign material to enter the engine and damage it.
- Be sure to use designated element when replacing the air cleaner element.

The maximum air intake restriction, in terms of differential pressure measurement, must not exceed 0.90 psi (6.23 kPa; 635 mmAq). Clean or replace the air cleaner element if the air intake restriction exceeds the above mentioned value.

Engine Stop

For maximum engine life, YANMAR recommends that when shutting the engine down, you allow the engine to idle, without load, for five minutes. This will allow the engine components that operate at high temperatures, such as the turbocharger (if equipped) and exhaust system, to cool slightly before the engine itself is shut down.

Battery and Electrical Equipment

Always keep the battery in a best charged state. Electronic controlled engines may not be able to start.

Use a specialized battery charger to recharge a battery with a voltage of 8 volts or less. Booster starting a battery with a voltage of 8 volts or less will generate an abnormally high voltage and destroy electrical equipment.

When unavoidably using a rapid charger to recharge, do not insert and turn the starter key to ON position while the battery is being charged. Avoid using a charger equipped with a boost function (cell start support) to start the engine. Excessive voltage may be applied to the ECU of electronic controlled engines, resulting in damage to the ECU.

NOTICE

Removing the battery cables or the battery while the engine is operating may cause damage to the current limiter depending on the electrical equipment being used. This situation could cause loss of control of output voltage. The continuous high voltage of 23 - 24 volts (for 5000 min⁻¹ (rpm) dynamo) will damage the current limiter and other electrical equipment.

Reversing the battery cable connections at the battery or on the engine will destroy the SCR diode in the current limiter. This will cause the charging system to malfunction and may cause damage to the electrical harnesses.

Do not remove the positive (+) battery cable from alternator terminal B while the engine is operating. Damage to the alternator will result.

Do not turn the battery switch OFF (if equipped) while the engine is operating. Damage to the alternator will result.

Do not reverse the positive (+) and negative (-) ends of the battery cable. The alternator diode and stator coil will be damaged.

When the battery indicator goes out, it should not come on again. The battery indicator only comes on during operation if the alternator fails. However, if an LED is used in the battery indicator, the LED will shine faintly during normal operation.

Using a non-specified V-belt will cause inadequate charging and shorten the belt life. Use the specified belt.

Agricultural or other chemicals, especially those with a high sulfur content, can adhere to the IC regulator. This will corrode the conductor and result in battery over-charging (boiling) and charging malfunctions. Consult YANMAR before using the equipment in such an environment or the warranty is voided.

NOTICE

ECU (Engine Controller) of Electronic Controlled Engine

- Do not plug or unplug the ECU for a period of at least 60 seconds after power to the unit has been turned on or off.
 - Do not touch connector pins of the ECU with bare hands. Doing so may result in corrosion of the connector pins and/or damage to the internal circuits of the ECU due to static electricity.
 - Do not force a measuring probe into the female coupler. Doing so may cause contact failure of the connector pins, resulting in malfunction of the ECU.
 - Take care to prevent water from entering the couplers when plugging or unplugging the connector. Water inside the couplers may cause corrosion, resulting in malfunction of the ECU.
 - Avoid plugging/unplugging the connector more than approx. 10 times. Frequent plugging/unplugging of the connector may cause contact failure of the connector pins, resulting in malfunction of the ECU.
 - Do not use the ECU that has ever suffered drop impact.
 - Do not disassemble the ECU terminal.
-

High-pressure Cleaning

Put a cover to protect the air cleaner, turbocharger (if equipped) and electric components from damage when you use steam or high-pressure water to clean the engine.

Never use high-pressure water or compressed air at greater than 28 psi (193 kPa; 19686 mmAq) or a wire brush to clean the radiator fins. Radiator fins damage easily.

NOTICE

- Do not use a high-pressure cleaner directly on the alternator. Water will damage the alternator and result in inadequate charging.
- The starter motor is water-proofed according to JIS D 0203, R2 which protects the motor from rain or general cleaning. Do not use high-pressure cleaner or submerge the starter motor in water.
- Avoid using high-pressure cleaner for electronic or electric devices installed in, on or around the engine, including the ECU of electronic controlled engine, relays and harness couplers.

Otherwise such devices may suffer malfunction due to water ingress into them.

Periodic Maintenance

Establish a periodic maintenance plan according to the engine application and make sure you perform the required periodic maintenance at intervals indicated. Failure to follow these guidelines will impair the engine's safety and performance characteristics, shorten the engine's life and may affect the warranty coverage on your engine.

Periodic maintenance prevents unexpected downtime, reduces the number of accidents due to poor machine performance and helps extend the life of the engine.

The tightening torque in the *Standard Torque Chart in the Periodic Maintenance Section of this manual* should be applied only to the bolts with a "7" head. (JIS strength classification: 7T)

- For 4T bolts and locknuts, apply 60% of the torque listed in the table.
- If aluminum alloy is contained in the parts to be tightened, apply 80% of the torque listed in the table.

**NOTICE**

- Always be environmentally responsible.

- Follow the guidelines of the EPA or other governmental agencies for the proper disposal of hazardous materials such as engine oil, diesel fuel and engine coolant. Consult the local authorities or reclamation facility.
- Never dispose of hazardous materials irresponsibly by dumping them into a sewer, on the ground, or into ground water or waterways.
- Failure to follow these procedures may seriously harm the environment.

- Never attempt to modify the engine's design or safety features such as defeating the engine speed limit control.
- Never attempt to adjust the low or high idle speed limit screw. This may impair the safety and performance of the machine and shorten its life. If adjustment is ever required, contact your authorized YANMAR industrial engine dealer or distributor.
- Modifications may impair the engine's safety and performance characteristics and shorten the engine's life. Any alterations to this engine may void its warranty. Be sure to use YANMAR genuine replacement parts.

Operating the Engine or the Machine

- Never permit anyone to operate the engine or driven machine without proper training.
- Read and understand this Operation Manual before you operate or service the machine to ensure that you follow safe operating practices and maintenance procedures.
- Machine safety signs and labels are additional reminders for safe operating and maintenance techniques.

NOTICE

Precautions for Handling Desiccant

Disposal:

This material is disposable as non-flammable.

however, the bag is flammable and if it is necessary, then tear the bag and discard the bag and the contents separately.

It is desirable to bury the contents in the bag under ground.

Dispose in accordance with the disposal standards for industrial waste defined by local laws and regulations.

Handling:

The contents of the bag do not leak out in the normal use.

Take the following emergency measures, however, if the contents leak out.

- If the contents get on the skin, rinse thoroughly with running water.
- If the contents get in the eyes, rinse thoroughly with water. Consult with doctors when any abnormalities are found.
- If the contents get in the mouth, rinse thoroughly with water. Drink water to dilute if the content is swallowed, though a small amount is harmless. Consult with doctors when any abnormalities are found.

Characteristics of materials:

- Calcium Chloride (CaCl₂) Approx. 57%
- Grain Polysaccharide Approx. 28%
- Grain Skins Approx. 9%
- Ethylene Polymer (Bag) Approx. 5%

Hazard information:

- Explosiveness None
- Inflammability Inflammable
- Combustibility None
- Oxidation None

PRODUCT OVERVIEW

YANMAR TNV ENGINE FEATURES AND APPLICATIONS

YANMAR's series of TNM and TNV engines are environmentally friendly and are designed to:

- Lower the amount of exhaust gas emissions.
- Reduce engine noise and vibration.
- Be easy to start thanks to the specially designed fuel injection pump and combustion system.
- Be economical to run because diesel fuel and engine oil consumption are reduced.
- Be easy to operate due to the minimum amount of required maintenance and their compact design.
- Be durable and reliable due in part to the newly designed fuel injection valve and fuel injection pump.

YANMAR TNM and TNV engines are designed to supply power to a wide variety of driven machines including:

- Construction
- Agriculture
- Power generation

We are sure that you will agree these features provide excellent value in an industrial diesel engine.

These engines are designed to deliver power to driven machines by means of a "direct coupled drive" or "belt drive." In direct coupled drive engine applications, the engine's flywheel housing or end plate is coupled directly to the driven machine. In belt drive engine applications, a belt drive is used to power the driven machine. If you have applications that require a belt drive and/or front power take-off (PTO), please contact your authorized YANMAR industrial engine dealer or distributor.

The engine is designed for a wide range of applications. Options, such as fuel tank, control panel, indicators, gauges and alarms, are available to customize the application.

Since designing the application and installing the engine require special knowledge and skill, always consult your authorized YANMAR industrial engine dealer or distributor for these services. They will help you:

- Select optional equipment. Optional equipment should be selected to match the work conditions and environment.
- Maximize engine performance with a minimum amount of downtime and safety related incidents by carefully matching the characteristics of the engine with the driven machine.
- Plan for safe fuel piping, exhaust piping, electrical wiring, ventilation and accurate engine installation.
- Design your applications so they meet requirements of the local authorities.

COMPONENT IDENTIFICATION



Figure 1 shows where major indirect injection engine components are located.

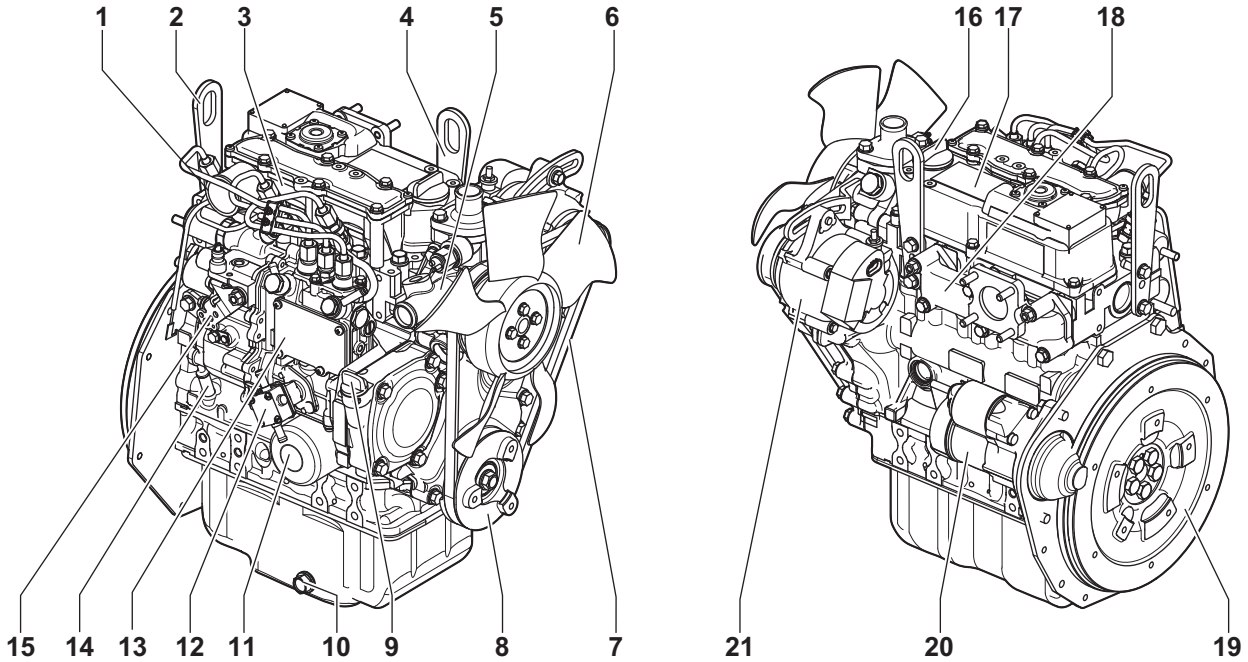

044905-00X

- | | |
|--|---|
| <ul style="list-style-type: none"> 1 – Air intake port (from air cleaner) 2 – Lifting eye (flywheel end) 3 – Intake manifold 4 – Lifting eye (engine cooling fan end) 5 – Engine coolant pump 6 – Engine cooling fan 7 – V-belt 8 – Crankshaft V-pulley 9 – Side filler port (engine oil) 10 – Drain plug (engine oil)*1 11 – Engine oil filter | <ul style="list-style-type: none"> 12 – Mechanical fuel pump 13 – Fuel injection pump 14 – Dipstick (engine oil) 15 – Governor lever 16 – Top filler port (engine oil) 17 – Rocker arm cover 18 – Exhaust manifold 19 – Flywheel 20 – Starter motor 21 – Alternator |
|--|---|

Figure 1

*1: Engine oil drain plug location may vary based on oil pan options.



3TNV74F, 3TNV76F, 3TNV80F

Figure 2 shows where major indirect injection engine components are located.

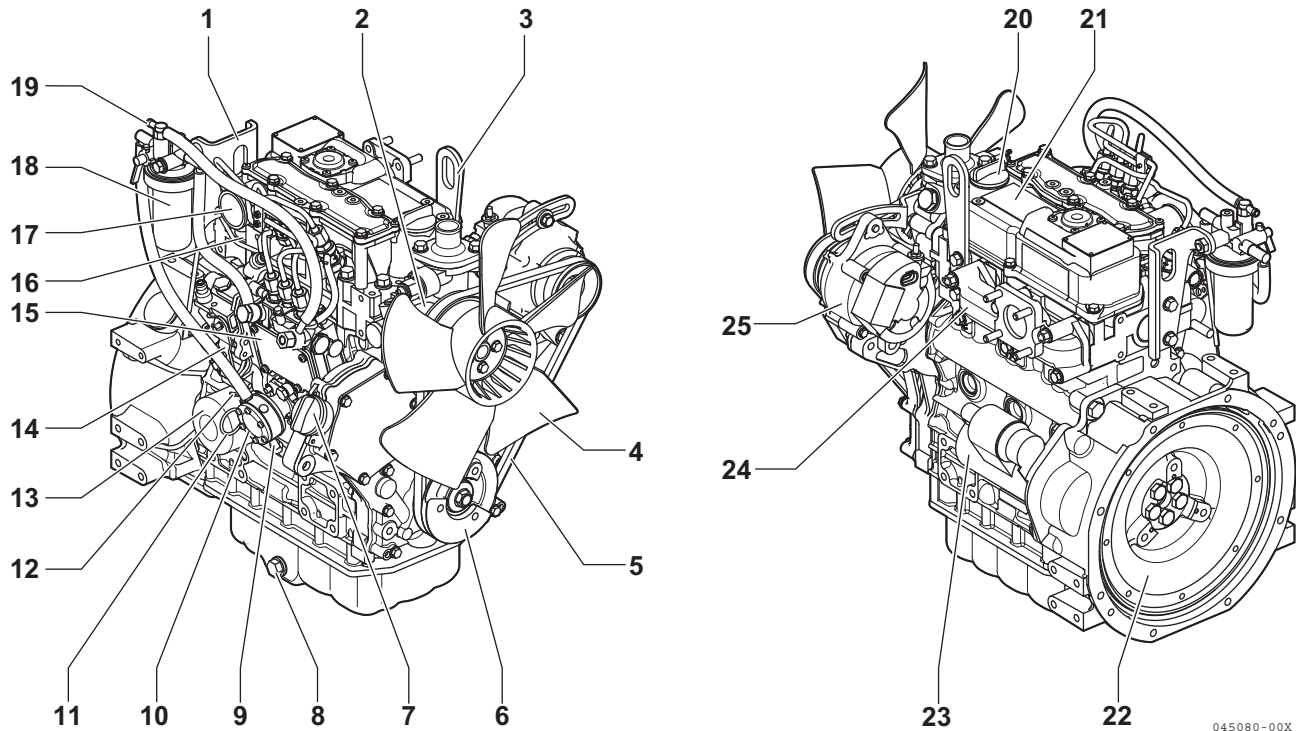

045080-00X

- | | |
|--|---|
| 1 – Lifting eye (flywheel end) | 14 – Governor lever |
| 2 – Engine coolant pump | 15 – Fuel injection pump |
| 3 – Lifting eye (engine cooling fan end) | 16 – Intake manifold |
| 4 – Engine cooling fan | 17 – Air intake port (from air cleaner) |
| 5 – V-belt | 18 – Fuel filter |
| 6 – Crankshaft V-pulley | 19 – Fuel return to fuel tank |
| 7 – Side filler port (engine oil) | 20 – Top filler port (engine oil) |
| 8 – Drain plug (engine oil)*1 | 21 – Rocker arm cover |
| 9 – Fuel inlet | 22 – Flywheel |
| 10 – Mechanical fuel pump | 23 – Starter motor |
| 11 – Dipstick (engine oil) | 24 – Exhaust manifold |
| 12 – Fuel priming lever | 25 – Alternator |
| 13 – Engine oil filter | |

Figure 2

*1: Engine oil drain plug location may vary based on oil pan options.

PRODUCT OVERVIEW



3TNV80FT

Figure 3 shows where major indirect injection engine components are located.

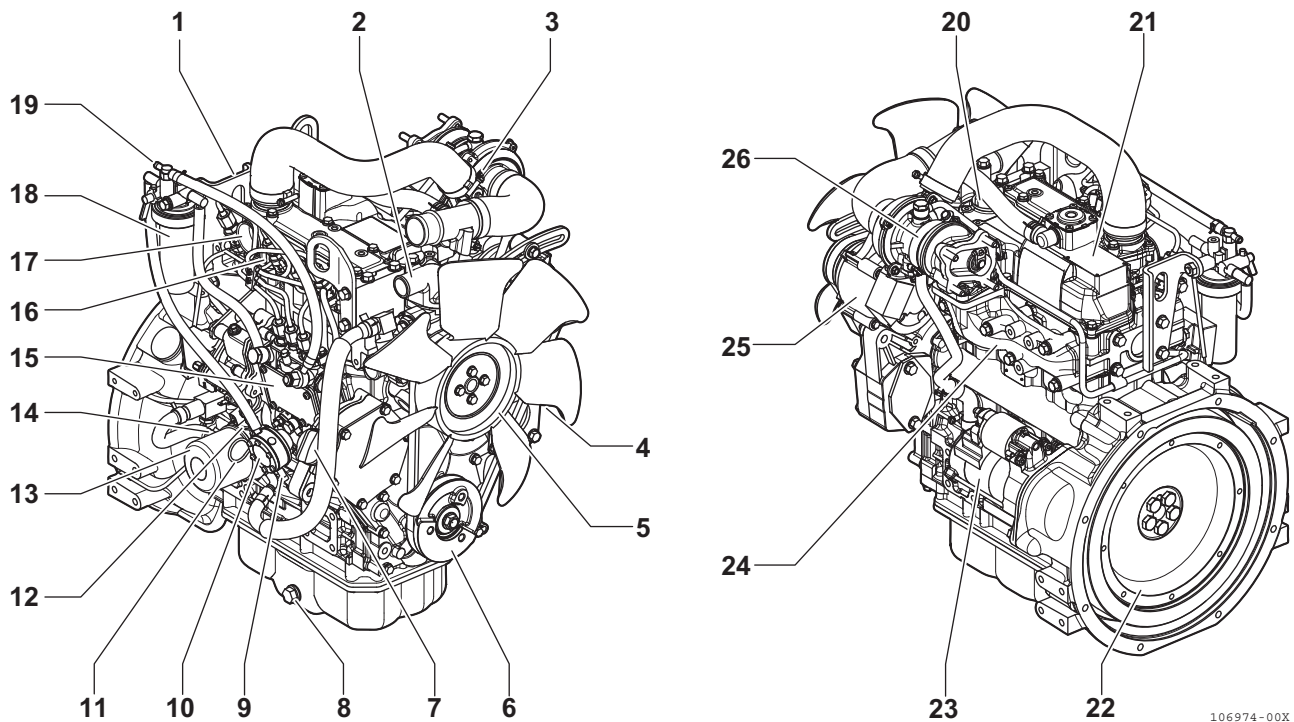

- 1 – Lifting eye (flywheel end)
- 2 – Engine coolant pump
- 3 – Lifting eye (engine cooling fan end)
- 4 – Engine cooling fan
- 5 – V-belt
- 6 – Crankshaft V-pulley
- 7 – Side filler port (engine oil)
- 8 – Drain plug (engine oil)*1
- 9 – Fuel inlet
- 10 – Mechanical fuel pump
- 11 – Dipstick (engine oil)
- 12 – Fuel priming lever
- 13 – Engine oil filter

- 14 – Engine oil cooler
- 15 – Fuel injection pump
- 16 – Intake manifold
- 17 – Air intake port (from air cleaner)
- 18 – Fuel filter
- 19 – Fuel return to fuel tank
- 20 – Top filler port (engine oil)
- 21 – Rocker arm cover
- 22 – Flywheel
- 23 – Starter motor
- 24 – Exhaust manifold
- 25 – Alternator
- 26 – Turbocharger

Figure 3

*1: Engine oil drain plug location may vary based on oil pan options.



3TNV88F

In **Figure 4**, each position of the major parts in the specification of 3TNV88F-E (Electronic controlled DI engine) is indicated. Note that, for 3TNV88F, there is another type known as 3TNV88F-U with mechanical governor DI, and the main parts are about the same without the “18-EGR valve”.

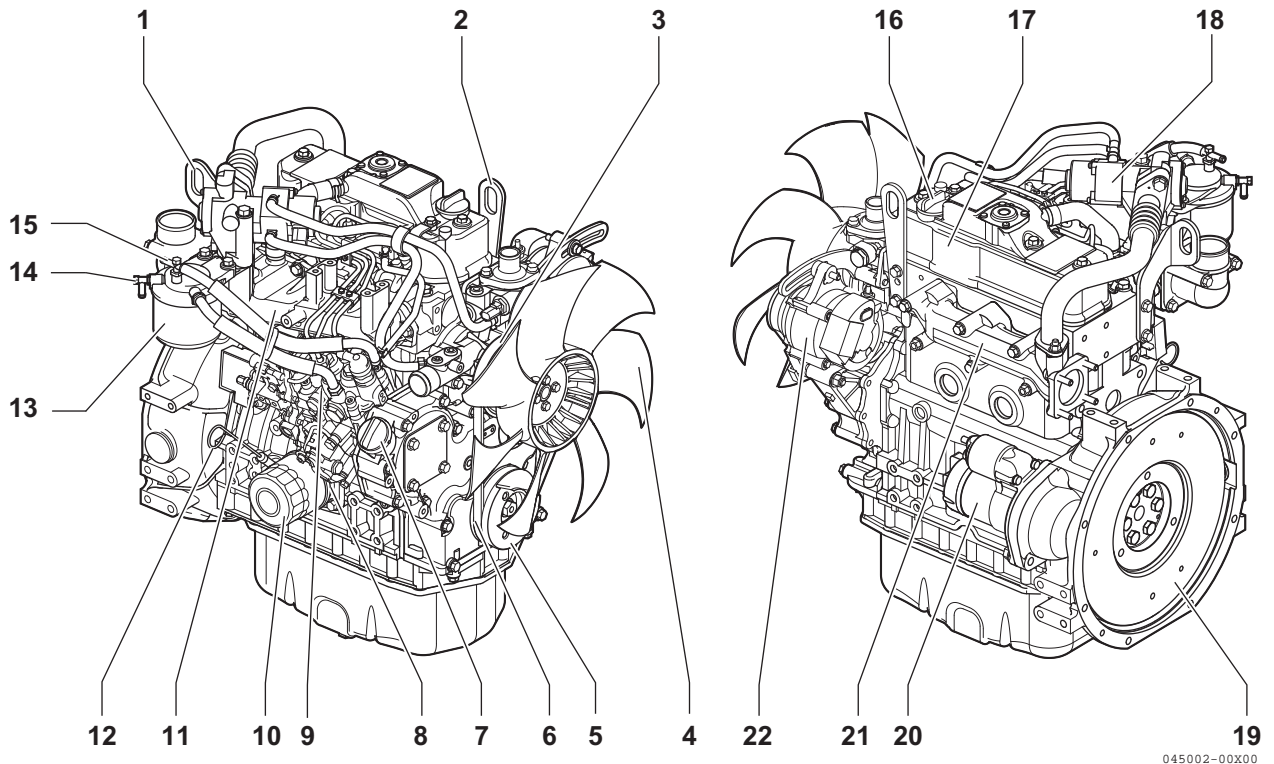

- 1 – Lifting eye (flywheel end)
- 2 – Lifting eye (engine cooling fan end)
- 3 – Engine coolant pump
- 4 – Engine cooling fan
- 5 – Crankshaft V-pulley
- 6 – V-belt
- 7 – Side filler port (engine oil)
- 8 – Engine oil cooler
- 9 – Fuel injection pump
- 10 – Engine oil filter
- 11 – Intake manifold

- 12 – Dipstick (engine oil)
- 13 – Fuel filter
- 14 – Fuel return to fuel tank
- 15 – Fuel inlet
- 16 – Top filler port (engine oil)
- 17 – Rocker arm cover
- 18 – EGR valve
- 19 – Flywheel
- 20 – Starter motor
- 21 – Exhaust manifold
- 22 – Alternator

Figure 4

*1: Engine oil drain plug location may vary based on oil pan options.

LOCATION OF LABELS



Figure 5 shows the location of engine nameplates and emission certification labels on YANMAR TNM and TNV series (3TNM74F, 3TNV74F, 3TNV76F, 3TNV80F, 3TNV80FT) indirect injection model engines.

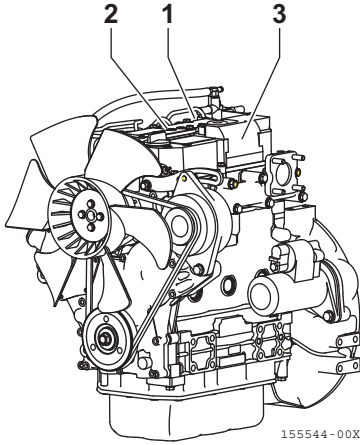

Figure 5

Typical location of the engine nameplate is on the top of the cylinder head cover. (1, **Figure 5**)

The typical location of the EPA/ARB certification label is on the top of the cylinder head cover. (2, **Figure 5**)

The typical location of the EU certification label is on the side face of engine cylinder head cover (exhaust side). (3, **Figure 5**)



Figure 6 shows the location of engine nameplates and emission certification labels on YANMAR TNV series (3TNV88F) direct injection model engine.

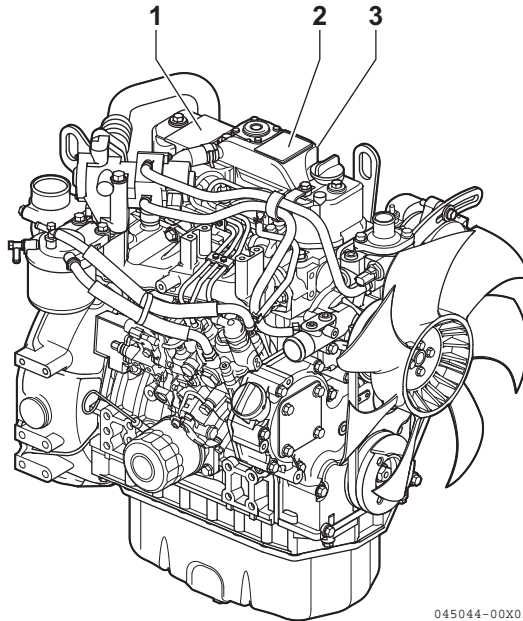
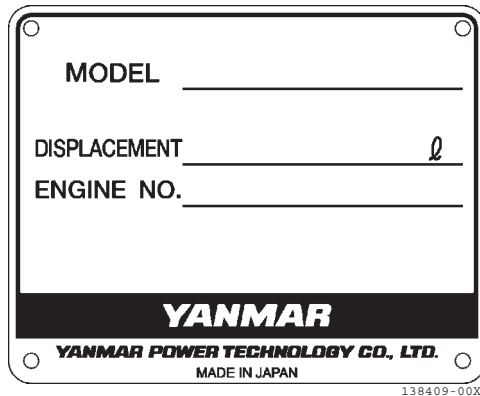

Figure 6

■ Location of labels/nameplates on direct injection model engines

Model	Engine nameplate	EPA/ARB certification label	EU certification label
3TNV88F	On the top of the locker arm cover (cooling fan end) (2, Figure 6)	On the top of the locker arm cover (flywheel end) (1, Figure 6)	Side faces of engine cylinder head cover (exhaust side) (3, Figure 6)

Engine Nameplate (Typical)



EMISSION CONTROL REGULATIONS

EPA/ARB Regulations - USA Only

YANMAR TNM and TNV engines meet Environmental Protection Agency (EPA) (U. S. Federal) emission control standards as well as the California Air Resources Board (ARB, California) regulations. Only engines that conform to ARB regulations can be sold in the State of California.

Refer to the specific EPA/ARB installation (page 77) and maintenance (page 77) in the *Periodic Maintenance Schedule* section of this manual. Also refer to the *EMISSION SYSTEM WARRANTY* on page 10.

EU Regulations

The engines described in this manual have been certified by the EU Regulation 2016/1628.

Note: This regulation is the amending of 97/68/EC directive as Stage V.

EMISSION CERTIFICATION LABELS

Since emission control regulations are being issued on a global basis, it is necessary to identify which regulations a particular engine complies with. We have listed several different types of labels you might find on your engine.

EPA/ARB Labels (Typical)

EPA: United States Environmental Protection Agency

ARB: California Air Resources Board

■ EPA

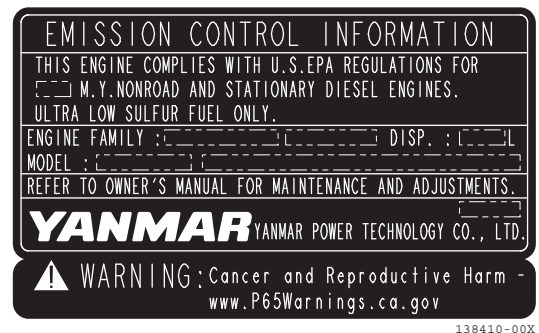

■ EPA and ARB

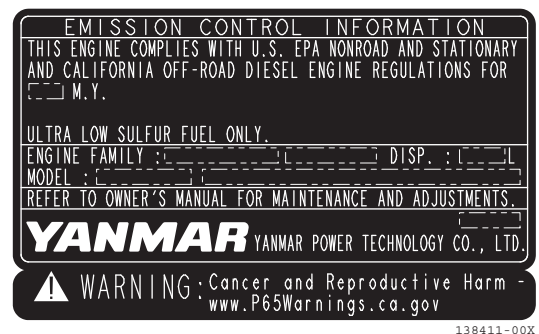

EU Labels (Typical)

■ EU Regulation 2016/1628

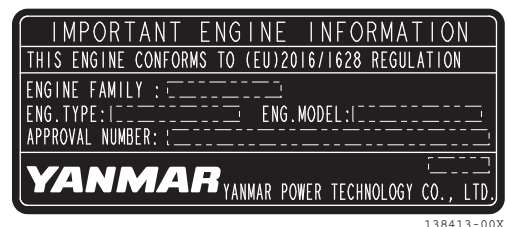

PRODUCT OVERVIEW

ENGINE FAMILY

The EPA/ARB labels have an Engine Family field.

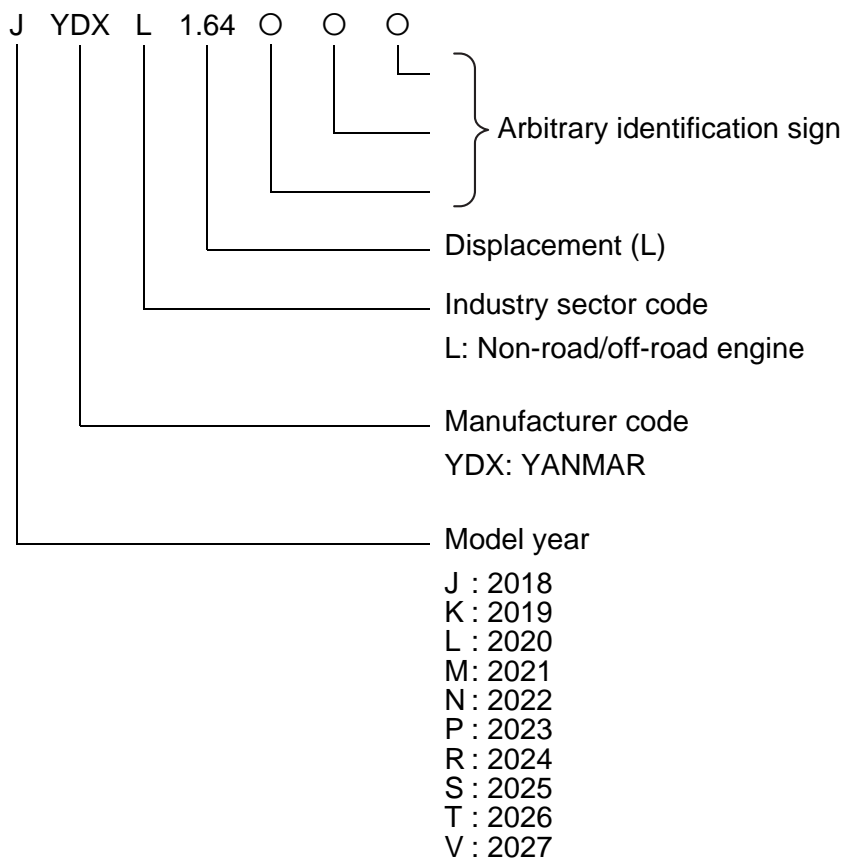

The following is an explanation of the Engine Family field designation:



FUNCTION OF MAJOR ENGINE COMPONENTS

Components	Functions
Air cleaner	The air cleaner prevents airborne contaminants from entering the engine. Since the air cleaner is application specific, it must be carefully selected by an application engineer. It is not part of the basic engine package as shipped from the YANMAR factory. Periodic replacement of the air cleaner filter element is necessary. See the <i>Periodic Maintenance Schedule on page 78</i> for the replacement frequency.
Starter motor	The starter motor is powered by the battery. When you turn the key switch in the operator's console to the START position, the starter motor engages with the ring gear installed on the flywheel and starts the flywheel in motion.
Alternator	The alternator is driven by a V-belt which is powered by the crankshaft V-pulley. The alternator supplies electricity to the engine systems and charges the battery while the engine is running.
Dipstick (engine oil)	The engine oil dipstick is used to determine the amount of engine oil in the crankcase.
Side and top filler port (engine oil)	You can fill the crankcase with engine oil from either the side or top filler port depending upon which one is most convenient.
Engine oil filter	The engine oil filter removes contaminants and sediment from the engine oil. Periodic replacement of the engine oil filter is necessary. See the <i>Periodic Maintenance Schedule on page 78</i> for the replacement frequency.
Engine oil cooler (Equipped to 3TNV88F and 3TNV80FT models)	The engine oil cooler helps to keep the engine oil cool. Engine coolant from the cooling system is circulated by the coolant pump through an adapter at the base of the engine to the oil cooler and then to the cylinder block and back to the coolant pump.
Fuel tank	The fuel tank is a reservoir that holds diesel fuel. When fuel leaves the fuel tank it goes to the water separator. Next, fuel is pumped to the fuel filter by the electric or mechanical fuel pump. Next the fuel goes to the fuel injection pump. Since fuel is used to keep the fuel injection pump cool and lubricated, more fuel than necessary enters the injection pump. When the injection pump pressure reaches a preset value, a relief valve allows excess fuel to be returned back to the fuel tank. The fuel tank is a required engine component.
Water separator	The water separator removes contaminants, sediment and water from diesel fuel going to the fuel filter. This is a required component of the fuel system and is standard equipment with every engine. The separator is installed between the fuel tank and the fuel pump. Periodically drain the water from the water separator using the drain valve at the bottom of the separator.
Electric fuel pump	The electric fuel pump makes sure there is a constant supply of diesel fuel to the fuel injection pump. The electric fuel pump is electro-magnetic and runs on 12 V DC. An electric fuel pump may be installed as an option or as standard equipment. Standard equipment may vary based on engine model and specification. If an electric fuel pump is installed, turn the key switch to the ON position for 10 to 15 seconds to prime the fuel system.

PRODUCT OVERVIEW

Components	Functions
 Mechanical fuel pump	The mechanical fuel pump is a diaphragm-type of pump and is installed on the fuel injection pump body. The mechanical fuel pump is driven by a cam on the camshaft of the fuel injection pump. An electric fuel pump is available as an option. The mechanical fuel pump is not installed on the fuel injection pump if the electric fuel pump option is installed.
 Fuel priming lever	If the unit has a mechanical fuel pump, a fuel priming lever on the mechanical fuel pump primes the fuel system. The fuel system needs to be primed before you start the engine for the first time, if you run out of fuel, or if fuel system service is performed. To prime the fuel system, operate the fuel priming lever until the cup in the fuel filter is full of fuel.
Fuel filter	The fuel filter removes contaminants and sediments from the diesel fuel. Periodic replacement of the fuel filter is necessary. <i>See the Periodic Maintenance Schedule on page 78</i> for the replacement frequency. Please note that the word “diesel” is implied throughout this manual when the word “fuel” is used.

FUNCTION OF COOLING SYSTEM COMPONENTS

Components	Functions
Cooling system	<p>The TNV engine is liquid-cooled by means of a cooling system. The cooling system consists of a radiator, radiator cap, engine cooling fan, engine coolant pump, thermostat, and reserve tank.</p> <p>Note that all cooling system components are required for proper engine operation. Since some of the components are application specific, they must be carefully selected by an application engineer. The application specific items are not part of the basic engine package as shipped from the YANMAR factory.</p>
<ul style="list-style-type: none"> • Engine cooling fan 	<p>The engine cooling fan is driven by a V-belt which is powered by the crankshaft V-pulley. The purpose of the engine cooling fan is to circulate air through the radiator.</p>
<ul style="list-style-type: none"> • Engine coolant pump 	<p>The engine coolant pump circulates the engine coolant through the cylinder block and cylinder head and returns the engine coolant to the radiator.</p>
<ul style="list-style-type: none"> • Radiator 	<p>The radiator acts as a heat exchanger. As the engine coolant circulates through the cylinder block it absorbs heat. The heat in the engine coolant is dissipated in the radiator. As the engine cooling fan circulates air through the radiator, the heat is transferred to the air.</p>
<ul style="list-style-type: none"> • Radiator cap 	<p>The radiator cap controls the cooling system pressure. The cooling system is pressurized to raise the boiling point of the engine coolant. As the engine coolant temperature rises, the system pressure and the coolant volume increases. When the pressure reaches a preset value, the release valve in the radiator cap opens and the excess engine coolant flows into the reserve tank. As the engine coolant temperature is reduced, the system pressure and volume is reduced and the vacuum valve in the radiator cap opens allowing engine coolant to flow from the reserve tank back into the radiator.</p>
<ul style="list-style-type: none"> • Reserve tank 	<p>The reserve tank contains the overflow of engine coolant from the radiator. If you need to add engine coolant to the system, add it to the reserve tank, not the radiator.</p>
<ul style="list-style-type: none"> • Thermostat 	<p>A thermostat is placed in the cooling system to prevent engine coolant from circulating into the radiator until the engine coolant temperature reaches a preset temperature. When the engine is cold, no engine coolant flows through the radiator. Once the engine reaches its operating temperature the thermostat opens and allows engine coolant to flow through the radiator. By letting the engine warm up as quickly as possible, the thermostat reduces engine wear, deposits and emissions.</p>

ELECTRONIC CONTROL SYSTEM



3TNV88F-E



3TNV80FT, 3TNV80F-Z

WARNING

- Never use the ECU for purposes that are not intended by YANMAR; such as using unauthorized ECU, writing unauthorized data to ECU, leaving it broken, or removing sensors and actuators. Doing so could result in the violation of emission control regulations and will void the product warranty.
- Be sure to use the ECU in conjunction with the engines whose models or serial numbers are specified by YANMAR. Other ECU/engine combinations than specified will void the engine warranty.
- Replacing the fuel injection pump involves rewriting the fuel injection data in the ECU. Be sure to contact your local YANMAR dealer before replacing the fuel injection pump. Failure to rewrite the fuel injection data before replacing the fuel injection pump will void the engine warranty.
- Replacing the ECU involves migrating the fuel injection data to the existing ECU to the new unit. Be sure to contact your local YANMAR dealer before replacing the ECU. Failure to migrate the fuel injection data before replacing the ECU will void the engine warranty.
- Improper use or misuse of the ECU may result in death or serious injury due to an abrupt and unexpected increase in engine speed.

NOTICE

Shut down the engine if the engine failure lamp comes on.

Continuing running the engine with the engine failure lamp being on may result in a serious malfunction of or damage to the engine, and will void the engine warranty.

NOTICE

Do not energize the starter for a period of longer than 15 seconds.

Take a pause of at least 30 seconds between energization of the starter.

Otherwise the starter could suffer damage.

NOTICE

- High-pressure washing not recommended.
- Avoid using high-pressure washing for electronic or electric devices installed in, on or around the engine, including the ECU, relays and harness couplers.

Otherwise such devices may suffer malfunction due to water ingress into them.

NOTICE

- Do not plug or unplug the ECU for a period of at least 6 seconds after power to the unit has been turned on or off.
- Do not touch connector pins of the ECU with bare hands. Doing so may result in corrosion of the connector pins and/or damage to the internal circuits of the ECU due to static electricity.
- Do not force a measuring probe into the female coupler. Doing so may cause contact failure of the connector pins, resulting in malfunction of the ECU.
- Take care to prevent water from entering the couplers when plugging or unplugging the connector. Water inside the couplers may cause corrosion, resulting in malfunction of the ECU.
- Avoid plugging/unplugging the connector more than approx. 10 times. Frequent plugging/unplugging of the connector may cause contact failure of the connector pins, resulting in malfunction of the ECU.
- Do not use the ECU that has ever suffered drop impact.
- Do not disassemble the ECU terminal.

NOTICE

Always check the battery for proper charge. Otherwise the electronic controlled engines may fail to start.

With 3TNV88F-E engines, the ECU (Engine Controller) controls the exhaust gas recirculation flow rate in the EGR system according to the engine load and engine speed.

The ECU also controls the fuel injection volume of the Eco-governor according to the engine operation conditions.

3TNV88F-E engines feature an electronic control system which combines the EGR system and Eco-governor. This system maintains optimal engine performance and ensures the cleanliness of the exhaust gas.

Figure 7 illustrates the outline of the electronic control system for 3TNV88F-E engines.

Features of the electronic engine control system include:

- Engine speed control schemes
Droop control/Low-idling speed up/Auto deceleration/High-idling speed down/Black smoke suppression
- Starting aid
Auto preheating/After heating
- Engine failure detection
- CAN communication with the control system of the driven machine
- Other

The above features are detailed in the table on the next pages.

Consult the operation manual for the driven machine for applicability of the features that depends on the machine.

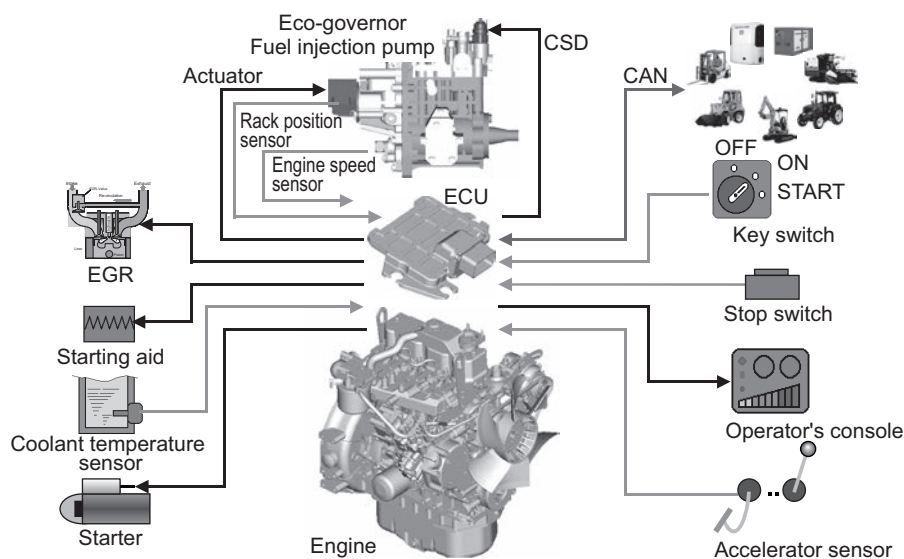

Figure 7

PRODUCT OVERVIEW

3TNV80FT engines conform to engine emission regulations (EPA 2013 rules).

As with 3TNV88F-E engines, 3TNV80FT engines are equipped with an Eco-governor in which the fuel injection volume and engine speed are controlled by the ECU. By having the Eco-governor installed, optimal engine performance and the cleanliness of exhaust gas are maintained.

Figure 8 illustrates the outline of the electronic control system for 3TNV80FT engines.

3TNV80FT engines are not equipped with an EGR or CSD.

As with 3TNV88F-E engines, the electronic engine control system for 3TNV80FT engines includes the following application functions.

- Engine speed control schemes
Droop control/Low-idling speed up/Auto deceleration/High-idling speed down/Black smoke suppression
- Starting aid
Auto preheating/After heating
- Engine failure detection
- CAN communication with the control system of the driven machine
- Other

The above features are detailed in the table on the next pages.

Consult the operation manual for the driven machine for applicability of the features that depends on the machine.

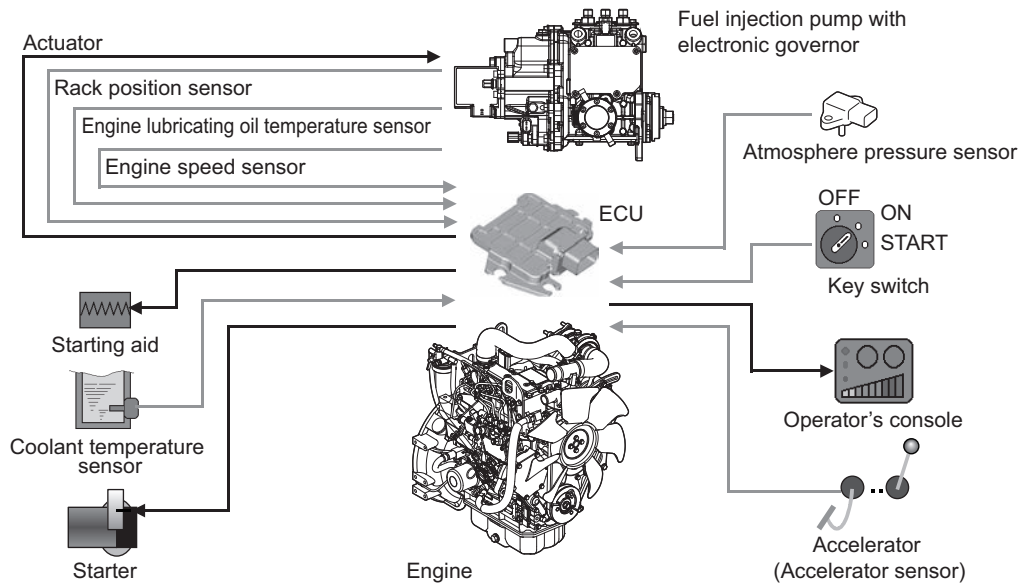

Figure 8

MAIN ELECTRONIC CONTROL COMPONENTS AND FEATURES



3TNV88F-E



3TNV80FT, 3TNV80F-Z

Component/feature		Description
ECU (Engine controller)		Adjusts the rack position of the fuel injection pump depending on the speed command signal from the accelerator sensor, thus regulating the engine speed and power. The ECU (engine controller) also regulates the opening of the EGR valve depending on the engine speed and power. It serves as the master station for the following components/control features.
Electronic governor (Eco-governor)		Consists of the engine speed sensor, rack actuator, etc., and is directly connected to the fuel injection pump in order to regulate the rack position of the fuel injection pump depending on the signals communicated with the ECU.
Fuel injection pump for Eco-governor	MP-type (3TNV88F-E)	Is of single plunger type and equipped with a CSD solenoid valve that allows the fuel injection timing to advance and the injection quantity to increase, thereby improving the cold start performance of the engine.
	ML-type (3TNV88FT, 3TNV80F-Z)	Provides optimal fuel injection to deliver engine performance and clean exhaust gas. Under cold weather conditions, fuel injection volume is increased based on signals from the ECU.
EGR valve (Equipped to 3TNV88F-E only)		Controls the exhaust gas recirculation flow rate depending on the engine speed/load signals from the ECU. It is installed on the top of the exhaust manifold.
Accelerator sensor		Unlike mechanical governors, the Eco-governor has no governor lever. The accelerator sensor serves as the governor lever to provide the speed command signal (voltage signal) to the ECU for engine speed control. It is installed in the operator cabin of the driven machine. Constant speed engines for e.g. generator use do not require accelerator sensors because the engine speed can be shifted via a switch on the operator's console.
Optional		CAN communication capability is available as an option.
Engine failure lamp		Is installed on the operator's console. If a fault occurs in the ECU or Eco-governor, the engine failure lamp flashes alerting the operator to a fault. The number of flashes and/or the flashing pattern vary depending on the type or source of the fault, enabling quick-fix.
Optional		
SMARTASSIST-DIRECT (SA-D) (Engine diagnosis tool)		Allows the operator to troubleshoot the cause of a problem based on detailed information regarding the problem occurring in the ECU or Eco-governor. This tool can also be used for data maintenance tasks including programming and mapping. <i>See Troubleshooting Chart on page 104.</i>
Option for service		

PRODUCT OVERVIEW

Component/feature		Description
Engine coolant temperature sensor		Allows the CSD and ERG to be controlled in engine cold-start conditions.
ON-glow at start	Optional	When the key switch is turned to the ON position, the glow plugs are energized for up to 15 seconds. The duration of energization depends on the engine coolant temperature. The HEAT indicator is on during energization. When the indicator goes out, turn the key switch to the START position to start the engine.
Droop control	Standard with VM series	Reduces the engine speed by a certain percentage from no load to full (rated) load in steady state operation. The same percentage droop is maintained even when the load increases at any no-load speed.
Isochronous control	Standard with CL series Optional with VM series	Offers a constant engine speed from no load to full load. The engine speed does not decrease even when the load increases at any no-load speed.
Low-idling speed up		Increases the low-idling speed to up to 1000 min ⁻¹ (rpm) depending on the engine coolant temperature. When the coolant temperature reaches a predetermined value, this feature returns the engine speed to the normal low idle setting, thus reducing the warm-up time.
High-idling speed down	Optional	Decreases the high-idling speed depending on the engine coolant temperature. When the coolant temperature falls to a predetermined value, this feature returns the engine speed to the normal high idle setting, thus minimizing the emission of white smoke at low temperatures.
Auto deceleration	Optional	Brings the running engine in low idle mode automatically when the accelerator pedal is not operated for a predetermined period of time. When the pedal is operated, i.e., the accelerator sensor is activated, the low idle mode is cancelled.

GAUGES AND INDICATORS

The operator's console provides you with the means to start and stop the unit and a series of gauges and indicators that inform you about the current status of the engine. This is a required engine component. Since the operator's console is application specific, it must be carefully selected by an application engineer. It is not part of the basic engine package as shipped from the YANMAR factory.

NOTICE

The illustrations and descriptions of optional equipment in this manual, such as the operator's console, are for a typical engine installation. Refer to the documentation supplied by the optional equipment manufacturer for specific operation and maintenance instructions.

Gauges

The following gauges are located on a typical operator's console. Some operator's consoles may not have the gauges described here or may have different gauges.

1 Tachometer

The tachometer display shows the engine speed in revolutions per minute (RPM).

2 Engine coolant temperature

The engine coolant temperature display shows the temperature of the engine coolant.

3 Engine oil pressure

The engine oil pressure display shows the pressure of the engine oil.

4 Hourmeter

The hourmeter display shows the total number of hours the engine has run. This is useful for planning the *Periodic Maintenance Procedures* on page 80.

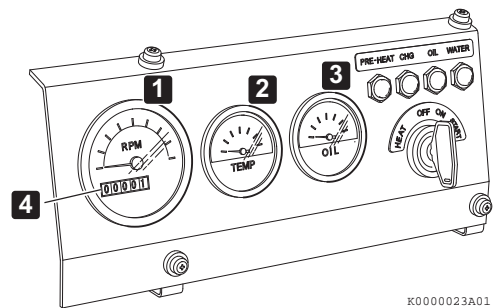

Figure 9

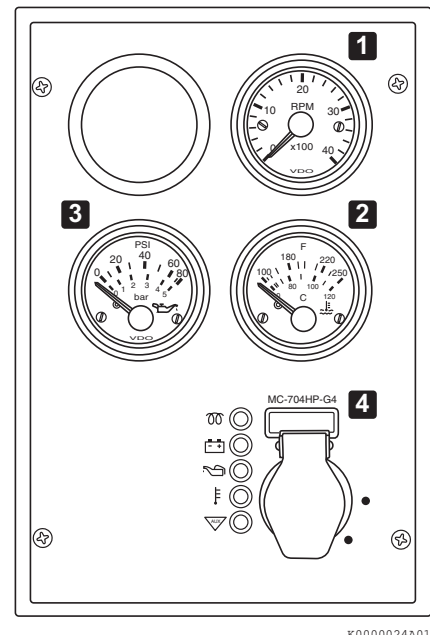

Figure 10

PRODUCT OVERVIEW

Indicators

The following indicators are located on a typical operator's console.

1 HEAT indicator (Standard glow (preheat) control)

When cold starting the engine, in order to activate the glow plug, the starter key needs to be turned to the HEAT position (left side of OFF) **7**. By turning the key to the HEAT position and keeping it at that position, the HEAT indicator **2** lights up, and after 4 seconds, it turns off. The time the indicator turns off is when to start the operation. In the case of 3TNV88F (DI), the indicator goes off after 15 seconds.

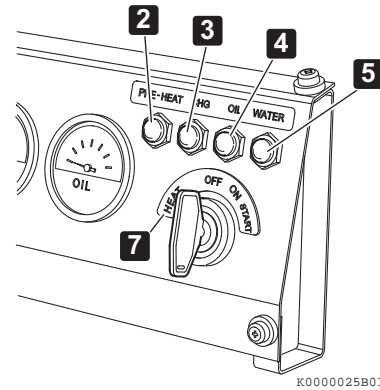

Figure 11

2 HEAT indicator (ON-glow control)

For the "ON-glow" type of the starter switch that does not have the HEAT position in the counterclockwise direction of the ON position, by turning the key to the ON position, the preheating function automatically activates, and the HEAT indicator **1** lights up. 4 seconds after the indicator turns off is when to start the operation. In the case of 3TNV88F (DI), the indicator goes off after 15 seconds. *Please refer to HEAT on page 47 about the HEAT indicator of the electronic controlled engine.*

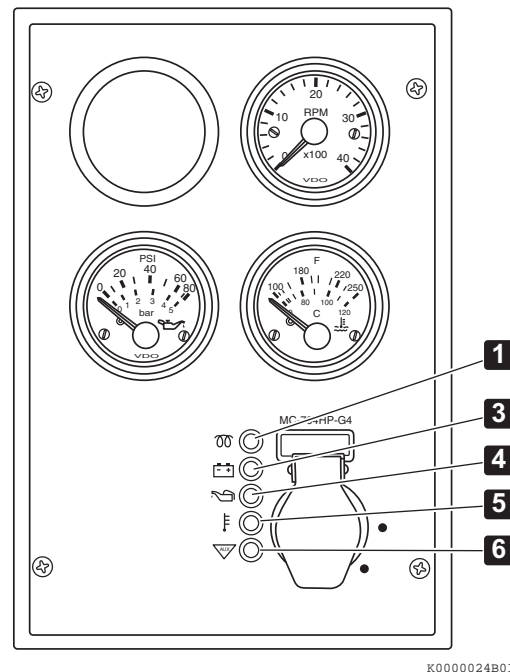

Figure 12

3 Battery charge

When the key is turned to the ON position, the charge indicator lights up. When the engine is started, the alternator (or dynamo) generates power, and the battery starts charging. Then the indicator goes off. This indicator will also come on when there is a problem in the charging system. This indicator does not tell you the charging timing (when the battery is low). *See Troubleshooting Chart on page 104.*

4 Engine oil pressure

This indicator will come on if the engine oil pressure is below or exceeds normal limits. *See Troubleshooting Chart on page 104.*

5 Engine coolant temperature

This indicator will come on if the engine coolant temperature exceeds normal limits. *See Troubleshooting Chart on page 104.*

6 Auxiliary

Used for special applications.

GAUGES AND INDICATORS OF ELECTRONIC CONTROL SYSTEM



3TNV88F-E



3TNV80FT, 3TNV80F-Z

Gauges

The following gauges are located on a typical operator's console of the electronic controlled engines. Some operator's consoles may not have the gauges described here or may have different gauges.

See the *Gauges and Indicators* section for description of indicators that are not described below.

Indicators

The following indicators are located on a typical operator's console.

1 Engine failure lamp (optional)

This indicator will flash if a fault occurs in the ECU or Eco-governor. The number of flashes and/or the flashing pattern vary depending on the type or source of the fault. See *Troubleshooting Chart* on page 104.

2 Auxiliary

Reserved as an optional fault indicator.

3 HEAT

This indicator will come on when the glow plugs are energized when cold starting the engine. For the electronic controlled engine, by turning the key switch to the ON position 7, the ECU detects the temperature of the engine coolant, and the HEAT indicator turns on for a preset period of time (Maximum 15 seconds), then the glow plug will be preheated. The time the lamp came off is when to start the operation.

When an optional after heater is installed, it is energized for up to 80 sec. after the engine has started, during which, however, the indicator is not on.

NOTICE

The illustrations and descriptions of optional equipment in this manual, such as the operator's console, are for a typical engine installation. Refer to the documentation supplied by the optional equipment manufacturer for specific operation and maintenance instructions.

Others (optional)

Other optional indicators including those for indicating the air cleaner is clogged or the water separator is filled with water can also be installed on the console. See the operation manual for the driven machine for details.

Machine events including alarms and faults are all stored in memory of the ECU and can be loaded into the service tool.

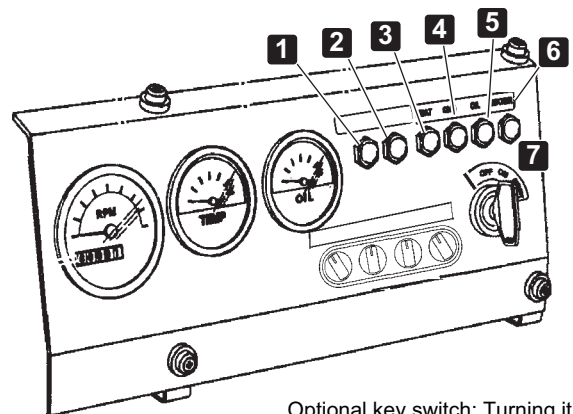

Optional key switch: Turning it to ON energizes the glow plugs automatically.

Figure 13

Note: Figure 13 Typical operator's console.

CONTROLS

Key Switch

The key switch for the operator's console illustrated in **Figure 14** has four positions - OFF, ON, START, and HEAT.

1 OFF (key straight up and down)

When you turn the key to this position the engine shuts down. Electric current to the gauges and indicators is shut off. You can insert and remove the key in this position.

2 ON

This is the position the key will be in when the engine is running. When the engine is not running, use this position to energize the gauges, indicators, electric fuel pump and auxiliary devices.

3 START

Turn the key to this position to start the engine. As soon as the engine starts, release the key and it will automatically return to the ON position. Some key switches may be equipped with a feature that prevents you from turning the key to the START position while the engine is running. When operating a key switch with this feature, you cannot turn the key to the START position without first returning the key to the OFF position.

4 HEAT

You must turn the key to the HEAT position to activate the glow plug. The indicator will flash for several seconds when you turn the key to HEAT. You can turn the key to START when the indicator goes out.

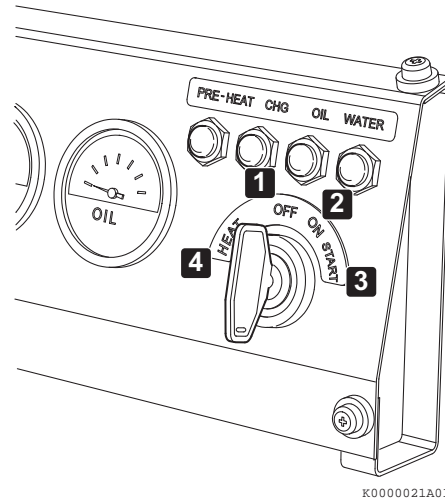

Figure 14

NOTICE

For maximum engine life, YANMAR recommends that when shutting the engine down, you allow the engine to idle, without load, for five minutes. This will allow the engine components that operate at high temperatures, such as the turbocharger (if equipped) and exhaust system, to cool slightly before the engine itself is shut down.

NOTICE

Never hold the key in the START position for longer than 15 seconds or the starter motor will overheat.

The key switch for the operator's console illustrated in **Figure 15** has three positions - OFF, ON and START.

1 OFF (key straight up and down)

2 ON

This is the position the key will be in when the engine is running. When the engine is not running, use this position to energize the gauges, indicators, electric fuel pump and auxiliary devices.

3 START

Turn the key to this position to start the engine. As soon as the engine starts, release the key and it will automatically return to the ON position. Some key switches may be equipped with a feature that prevents you from turning the key to the START position while the engine is running. When operating a key switch with this feature, you cannot turn the key to the START position without first returning the key to the OFF position.

NOTICE

For maximum engine life, YANMAR recommends that when shutting the engine down, you allow the engine to idle, without load, for five minutes. This will allow the engine components that operate at high temperatures, such as the turbocharger (if equipped) and exhaust system, to cool slightly before the engine itself is shut down.

NOTICE

Never hold the key in the START position for longer than 15 seconds or the starter motor will overheat.

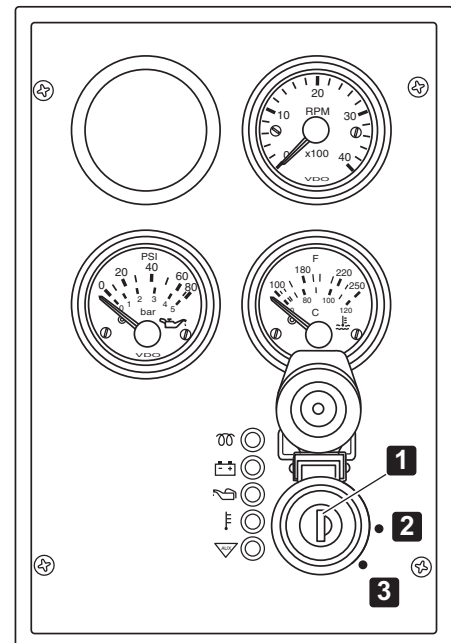

Figure 15

PRODUCT OVERVIEW

Glow Plugs

Glow plugs help make the engine easy to start at cold temperatures. During the engine starting sequence, the glow plugs are activated for approximately 4 seconds (15 seconds in case of 3TNV88F). After the pre-heat indicator goes out, the engine can be started.

These plugs are installed in the cylinder head swirl chambers for IDI engines or in the combustion chambers for DI engines.

Governor Lever

3TNM74F
3TNV74F
3TNV80F
3TNV88F-U

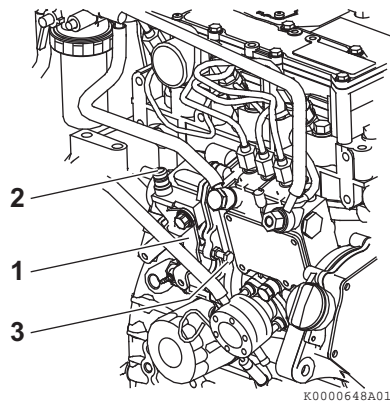

Figure 16

NOTICE

Never attempt to adjust the low or high idle speed limit screw. This may impair the safety and performance of the machine and shorten its life. If adjustment is ever required, contact your authorized YANMAR industrial engine dealer or distributor.

The governor lever (1, **Figure 16**) controls the engine speed. The lever is linked to the engine speed control device in the driven machine.

The high idle speed limit screw (2, **Figure 16**) restricts the maximum engine speed when the engine is operated without a load.

The low idle speed limit screw (3, **Figure 16**) sets engine speed while it is idling.

Engine Stop Solenoid

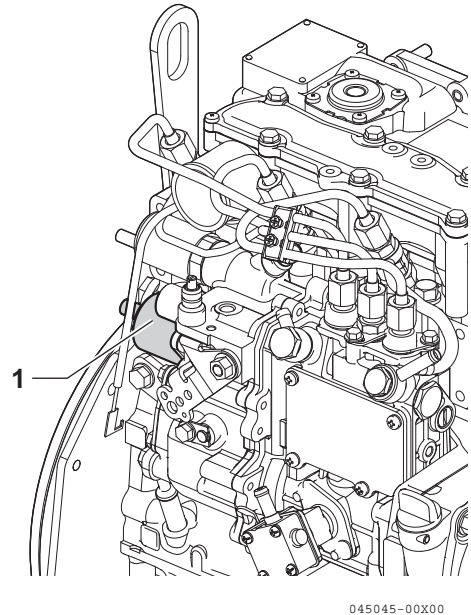

Figure 17

When the key is turned to the ON position, the engine stop solenoid (1, **Figure 17**) is energized and allows the fuel injection pump to deliver fuel to the engine, allowing the engine to be started. When the key is turned to the OFF position, the engine stop solenoid is de-energized and shuts off the fuel supply from the fuel injection pump to the engine, causing the engine to stop.

Electronic Engine Speed Control



3TNV88F-E



3TNV80FT,
3TNV80F-Z

Speed control of electronic controlled engines

The electronic controlled engines have no governor lever. For these engines, the position signal of the throttle lever or accelerator pedal of the driven machine is converted into an electric signal by the accelerator sensor **Figure 18**, which is then delivered to the rack actuator of the Eco-governor **Figure 20** through the ECU **Figure 19**, allowing the engine speed to be controlled.

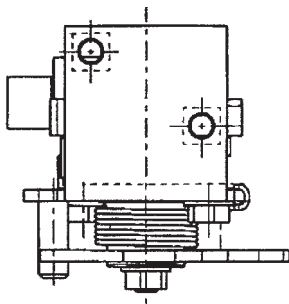

Figure 18

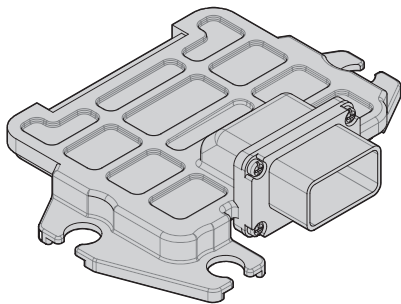

Figure 19

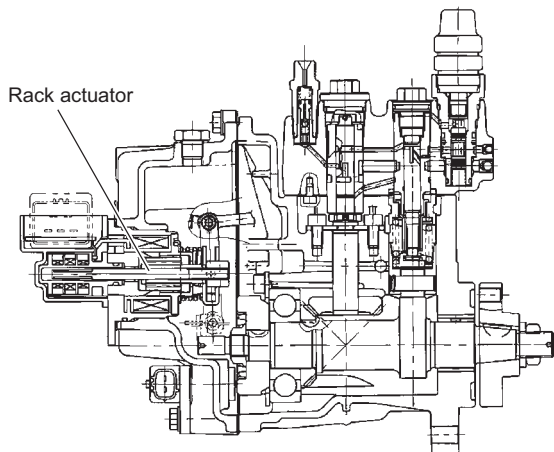

Figure 20

Start and stop of electronic controlled engines

The electronic controlled engines have no engine stop solenoid. The ECU controls the engine start/stop sequence.

Engine performance curves

Figure 21 shows typical engine speed curves that outline the relationship between engine speed and load.

Droop control

The VM series engines for general use are designed so that the engine speed is reduced by a certain percentage from 30% load to full rated load. See curves (1) in **Figure 21** below. The same percentage droop is maintained at any no-load speed.

Isochronous control

The CL series consists of isochronous design engines, the speed of which is kept constant from no load to full rated load. See curves (2) in **Figure 21** below.

Some VM series engines for general use may be custom-engineered and have the isochronous capability. Consult the operation manual for the driven machine for application details of such engines.

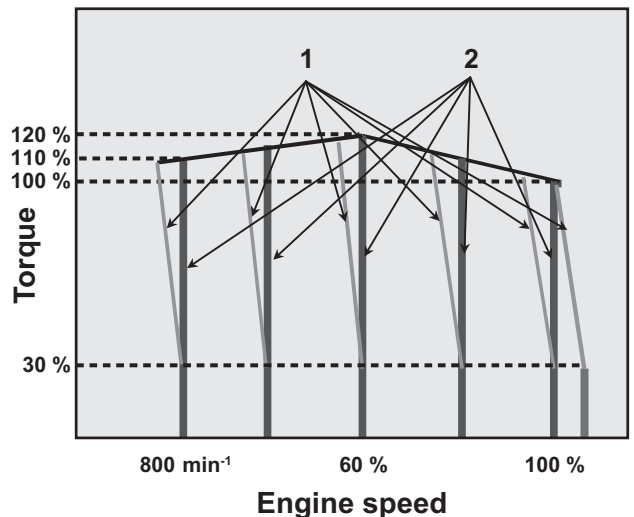

Figure 21

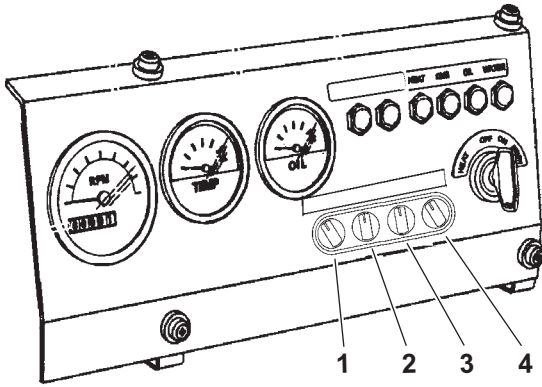

Figure 22

*Note: **Figure 22** Typical operator's console and switch arrangement.*

Low-idling speed up

This feature increases the low-idling speed to some extent depending on the engine coolant temperature. When the coolant temperature reaches a predetermined value, this feature returns the engine speed to the normal low idle setting, thus reducing the warm-up time.

Auto deceleration (optional)

This feature brings the running engine in low idle mode automatically when the accelerator pedal is not operated for a predetermined period of time. When the pedal is operated, i.e., the accelerator sensor is activated, the low idle mode is cancelled.

A certain ON/OFF combination of switches (1) - (4) on the operator's console **Figure 22** will implement this optional feature. For details, see the operation manual for the driven machine.

High-idling speed down (optional)

This feature decreases the high-idling speed depending on the engine coolant temperature. When the coolant temperature falls to a predetermined value, this feature returns the engine speed to the normal high idle setting, thus minimizing the emission of white smoke at low temperatures.

A certain ON/OFF combination of switches (1) - (4) on the operator's console **Figure 22** will implement this optional feature. For details, see the operation manual for the driven machine.

Others

Other optional features can be provided by selecting certain ON/OFF combinations of switches (1) - (4) on the operator's console **Figure 22** will implement this optional feature. For details, see the operation manual for the driven machine.

BEFORE YOU OPERATE

This section of the Operation Manual describes the diesel fuel, engine oil, and engine coolant specifications and how to replenish them. It also describes the daily engine checkout.

DIESEL FUEL

Diesel Fuel Specifications

Diesel fuel should comply with the following specifications. The table lists several worldwide specifications for diesel fuels.

Diesel fuel specification	Location
ASTM D975 No. 1D S15 No. 2D S15	USA
EN590 (2009)	European Union
ISO 8217 DMX	International
BS 2869-A1 or A2	United Kingdom
JIS K2204 Grade No. 2	Japan
KSM-2610	Korea
GB19147-2016	China

■ Additional technical fuel requirements

- When operating the engine in cold districts or high altitudes, the fuel cetane number should be equal to 45 or higher.
- **The sulfur content must not exceed 15 ppm by mass. A higher sulfur content fuel may cause sulfuric acid corrosion in the cylinders of the engines. Especially in U.S.A. and Canada, Ultra Low Sulfur fuel must be used.**
- In EU, sulfur content shall not exceed 10 ppm (15 ppm at point of final distribution).
- Use the fuel that can be used where the temperature is 12 °C (21.6 °F) lower than the expected lowest temperature to prevent the fuel from freezing.
- Bio-diesel fuels. See *Biodiesel fuels on page 55*.
- Water and sediment in the fuel should not exceed 200 mg/kg.
- Ash content not exceed 0.01% by mass.
- Carbon residue content not to exceed 0.35% by mass. Less than 0.1% is preferred.
- Total aromatics content should not exceed 35% by volume. Less than 30% is preferred.

- PAH (Polycyclic Aromatic Hydrocarbons) content should be below 10% by volume.
- Metal content of Mg, Si, and Al should be equal to or lower than 1 mass ppm. (Test analysis method JPI-5S-44-95)
- The diesel fuel should be free from Zn and Na.
- Lubricity: Wear mark of WS1.4 should be Max. 0.018 in. (460 µm) at HFRR test.

■ Precautions and concerns regarding the use of diesel fuel

- Never use kerosene.
- Never mix kerosene or used engine oil with the diesel fuel.
- Never use residual fuels that cause diesel fuel filter clogging and carbon deposits on the nozzles.
- Never use fuels stored for long time in a drum can or the like.
- Never keep fuel in containers with zinc plating on the inside.
- Never use fuels purchased from unauthorized dealer.
- Fuel additives are not recommended. Some fuel additives may cause poor engine performance. Fuel additives containing alcohol content, such as drainage agent etc. have adverse effects on the sealing section, and it will result in fuel leaks. Consult your YANMAR representative for more information.

■ Biodiesel fuels

1. General Description of Biodiesel

(a) Biodiesel is a renewable, oxygenated fuel made from agricultural and renewable resources such as soybeans or rapeseeds. Biodiesel is a fuel comprised of methyl or ethyl ester-based oxygenates of long chain fatty acids derived from the transesterification of vegetable oils, animal fats, and cooking oils. It contains no petroleum-based diesel fuel but can be blended at any level with petroleum-based diesel fuel. In case it is not blended with petroleum-based diesel fuel such biodiesel is referred to as “B100”, which means that it consists of 100 % (pure) biodiesel. However, most common biodiesel is blended with conventional (petroleum-based) diesel fuel. The percentage of the blend can be identified by its name. For example, B7 consisting of 7 % biodiesel and 93 % conventional petroleum-based diesel fuel and B20 consisting 20 % biodiesel and 80 % conventional diesel fuel. Raw pressed vegetable oils are not considered to be biodiesel.

(b) Advantages of Biodiesel:

- Biodiesel produces less visible smoke and a lower amount of particulate matter.
- Biodiesel is biodegradable and nontoxic.
- Biodiesel is safer than conventional diesel fuel because of its higher flash point.

Following the increased interest in the reduction of emissions and the reduction of the use of petroleum distillate based fuels; many governments and regulating bodies encourage the use of biodiesel.

(c) Disadvantages of Biodiesel:

Concentrations that are higher than 7 % of biodiesel (higher than B7) can have an adverse affect on the engine’s performance, its integrity and/or durability. The risk of problems occurring in the engine increases as the level of biodiesel blend increases. The following negative affects are exemplary and typical for the usage of high concentrated biodiesel blends:

- Biodiesel can accelerate the oxidation of Aluminum, Brass, Bronze, Copper and Zinc.

- Biodiesel damages, and finally seeps through certain seals, gaskets, hoses, glues and plastics.
- Certain natural rubbers, nitride and butyl rubbers will become harder and more brittle as degradation proceeds when used with biodiesel.
- The deteriorated biodiesel creates deposits in the engines.
- Due to its natural characteristic, biodiesel will decrease the engine output by approximately 2 percent (in case of B20) comparing to conventional (petroleum-based) diesel fuel.
- The fuel consumption ratio will increase by approximately 3 percent (in case of B 20) comparing to conventional diesel fuel.

2. Approved Engines

All of the following engine series of YANMAR can be operated with biodiesel with concentrations up to B20. In case of using biodiesel fuel up to B7 concentrations, no special preparations etc. have to be made and the original operating conditions and service intervals as stated in the operating manuals apply. In case of running below indicated engines with biodiesel concentrations above B7 up to B20, the required operating conditions (see below No. 4) have to be observed.

The following listed engines can be run with B20 biodiesel:

Group A	3TNM68, 3TNM72, 2TNV70, 3TNV70, 3TNV76(F)
	3TNV82A, 3TNV84(T), 3TNV88, 4TNV84(T)
	4TNV88, 4TNV94L, 4TNV98(T), 4TNV106(T)
	4TNE92, 4TNE94L, 4TNE98 (For forklift)
Group B	3TNM74F, 3TNV74F, 3TNV80F(T), 3TNV88F
	3TNV88C, 4TNV88C, 4TNV98C(T)
	3TNV86C(H)T, 4TNV86C(H)T 4TNV94HT, 4TNV94CHT, 4TNV94FHT

BEFORE YOU OPERATE

3. Approved Fuel

In case of using biodiesel (only concentrations up to B20) such fuel should comply with the below recommended standards. However, raw pressed vegetable oils are not considered to be biodiesel and are not acceptable for use as fuel in any concentration in YANMAR engines.

(a) EN14214 (European standard) and/or ASTM D-6751 (American standard).
In North America, biodiesel and biodiesel blends must be purchased from the BQ-9000 accredited producers and BQ-9000 certified distributors.

(b) All applicable engines can be operated with biodiesel fuels with concentration levels up to B20 (20 % bio-fuel blend). (However in Japan, the legally allowed maximum concentration for on-road applications is B5.)

If the concentration is B7 (7 %) or lower, the fuel can be used for all of the YANMAR's industrial engines, and does not require any special preparations or operating conditions. However, please strictly follow the standard operating conditions included in the manual.

4. Conditions for the Operation with Biodiesel (above B7 through B20)

When operating your applicable YANMAR engine (No. 2) with biodiesel blends concentrated above B7, we seriously recommend observing the following operation, service and maintenance conditions:

(a) The original service interval of the below stated services as indicated in the respective YANMAR engine standard operation manual and the service manual should be halved (please refer to your own manuals for the each service interval):

- Replacement interval of the fuel filter.
- Cleaning interval of the water separator.
- Draining interval of the fuel tank.

(b) Have the fuel injector inspected and cleaned every 1000 hours.

It is strongly recommended to replace the fuel hoses after 2000 operating hours or 2 years whichever comes first same as conventional diesel fuel used.

(c) Replacement of the following parts before using the recommended biodiesel:
(only for the operation with biodiesel above B10 through B20)

- Group A
 - (1) Fuel hose (the recommended material of the hose is to fluoro rubber (FKM))
 - (2) Fuel feed pump (Diaphragm type)
 - (3) If not already installed, a water separator needs to be built in
 - (4) O-ring of fuel filter
 - (5) O-ring of water separator

- Group B
 - (1) O-ring of water separator

(d) Please use only biodiesel fuel that is appropriate to the intended operation environment of the engines. This especially applies if the operating ambient temperature falls below 0 degree centigrade.

- (e) In particular, operation with biodiesel requires daily maintenance as follows:
1. Please daily check the engine oil level. If the oil level rises above the oil level of the previous day, the engine oil needs to be immediately replaced.
 2. Please daily check the water level of the water separator. If the water level rises above the "max" indicator, an immediate drain of the water separator is required.

(f) Biodiesel blends up to B20 can only be used for a limited time of up to 3 months of the date of biodiesel manufacture. Therefore biodiesel needs to be used at latest within 2 months from the time of filling the tank or within 3 months from the time of production by the fuel supplier, whichever comes first.

(g) Before a long-term storage without operating the engine, the biodiesel needs to be drained out completely and the engine has to be run for 30 minutes with conventional diesel fuel as indicated in your operation manual.

The summary of difference for operation condition by blends and models which is mentioned above are as follows. For details, refer to (C) above.

Blends	Service interval	Parts exchange	Model
- B7	Same as standard	Not required	All YANMAR industrial models
B8 - B10	Half of standard	Not required	Group A and Group B
B11 - B20	Half of standard	Required (Refer (C) in detail)	Group A and Group B

Standard: Same as when using the diesel fuel

Filling the Fuel Tank

⚠ DANGER

Fire and Explosion Hazard!



- Diesel fuel is flammable and explosive under certain conditions.

- Only fill the fuel tank with diesel fuel. Filling the fuel tank with gasoline may result in a fire and will damage the engine.
- Never refuel with the engine running.
- Wipe up all spills immediately.
- Keep sparks, open flames or any other form of ignition (match, cigarette, static electric source) well away when refueling.
- Never overfill the fuel tank.
- Fill the fuel tank. Store any containers containing fuel in a well-ventilated area, away from any combustibles or sources of ignition.
- Be sure to place the diesel fuel container on the ground when transferring the diesel fuel from the pump to the container. Hold the hose nozzle firmly against the side of the container while filling it. This prevents static electricity buildup which could cause sparks and ignite fuel vapors.
- Never place diesel fuel or other flammable material such as oil, hay or dried grass close to the engine during engine operation or shortly after shutdown.
- Before you operate the engine, check for fuel leaks. Replace rubberized fuel hoses every two years or every 2000 hours of engine operation, whichever comes first, even if the engine has been out of service. Rubberized fuel lines tend to dry out and become brittle after two years or 2000 hours of engine operation, whichever comes first.
- Failure to comply will result in death or serious injury.

NOTICE

- Poor quality fuel can reduce engine performance and cause damage. Only use diesel fuels recommended by YANMAR for the best engine performance. The recommended fuel complies with the U.S. EPA and ARB protection guidelines.
- Keep the fuel tank and fuel-handling equipment clean at all times. Be careful not to let any contaminants or even dust from the outside into the filler port when supplying fuel.
- Never remove the primary strainer (if equipped) from the fuel tank filler port. If removed, dirt and debris could get into the fuel system causing it to clog.

Note that a typical fuel tank is shown. The fuel tank on your equipment may be different.

1. Clean the area around the fuel cap (1, **Figure 1**).
2. Remove the fuel cap from the fuel tank (2, **Figure 1**).
3. Observe the fuel level sight gauge (3, **Figure 1**) and stop filling when gauge shows fuel tank is full. Never overfill the fuel tank.
4. Replace the fuel cap (1, **Figure 1**), hand tighten. Over tightening the fuel cap will damage it.

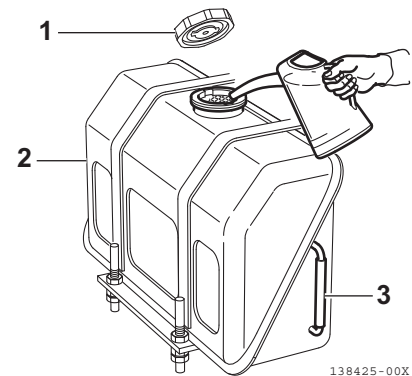

Figure 1

BEFORE YOU OPERATE

Priming the Fuel System

DANGER

Fire and Explosion Hazard!

- Diesel fuel is flammable and explosive under certain conditions.



- If the unit has an electric fuel pump, when you prime the fuel system, turn the key switch to the ON position for 10 to 15 seconds to allow the electric fuel pump to prime the system.
- If the unit has a mechanical fuel pump, when you prime the fuel system, operate the fuel priming lever of the mechanical fuel pump several times until the fuel filter cup is filled with fuel.
- Failure to comply will result in death or serious injury.



The fuel system needs to be primed under certain conditions:

- Before starting the engine for the first time
- After running out of fuel and fuel has been added to the fuel tank
- After fuel system maintenance such as changing the fuel filter and draining the water separator, or replacing a fuel system component.

To prime the fuel system if an electric fuel pump is installed:

1. Turn the key to the ON position for 10 to 15 seconds. This will allow the electric fuel pump to prime the fuel system.
2. Never use the starter motor to crank the engine in order to prime the fuel system. This may cause the starter motor to overheat and damage the coils, pinion and/or ring gear.

To prime the fuel system if a mechanical fuel pump is installed:

1. Operate the fuel priming lever (1, **Figure 2**) several times until the fuel filter cup (2, **Figure 2**) is filled with fuel.
2. Never use the starter motor to crank the engine in order to prime the fuel system. This may cause the starter motor to overheat and damage the coils, pinion and/or ring gear.

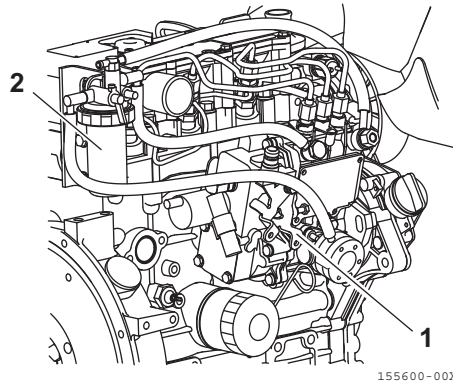

Figure 2



The fuel system needs to be primed under certain conditions:

- Before starting the engine for the first time
- After running out of fuel and fuel has been added to the fuel tank
- After fuel system maintenance such as changing the fuel filter and draining the water separator, or replacing a fuel system component.

To prime the fuel system:

1. Turn the key to the ON position for 10 to 15 seconds. This will allow the electric fuel pump to prime the fuel system.
2. Never use the starter motor to crank the engine in order to prime the fuel system. This may cause the starter motor to overheat and damage the coils, pinion and/or ring gear.

ENGINE OIL

NOTICE

- Only use the engine oil specified. Other engine oils may affect warranty coverage, cause internal engine components to seize and/or shorten engine life.
- Prevent dirt and debris from contaminating the engine oil. Carefully clean the oil cap/dipstick and the surrounding area before you remove the cap.
- Never mix different types of engine oil. This may adversely affect the lubricating properties of the engine oil.
- Never overfill. Overfilling may result in white exhaust smoke, engine overspeed or internal damage.

Engine Oil Specifications

Use an engine oil that meets or exceeds the following guidelines and classifications:

■ Service categories

- API service categories CD, CF, CF-4, CI-4 (Use an API CF or higher quality oil for electronic controlled engines.)
- ACEA service categories E-3, E-4, and E-5
- JASO service category DH-1

■ Definitions

- API classification (American Petroleum Institute)
- ACEA classification (Association des Constructeurs Européens d'Automobiles)
- JASO (Japanese Automobile Standards Organization)

NOTICE

- Be sure the engine oil, engine oil storage containers, and engine oil filling equipment are free of sediments and water.
- Change the engine oil
 1. at every 250 hours for 3TNV74F, 3TNV80F, 3TNV80FT and 3TNM74F model
 2. at every 500 hours or 1 year for 3TNV88F model

Maintenance interval has different standard dependent on the application or engine oil capacity. Refer to the operation manual provided by the driven machine manufacturer for the actual engine oil change interval.

- Select the oil viscosity based on the ambient temperature where the engine is being operated. See the SAE Service Grade Viscosity Chart (**Figure 3**).
- YANMAR does not recommend the use of engine oil "additives".

■ Additional technical engine oil requirements:

The engine oil must be changed when the Total Base Number (TBN) has been reduced to 1.0 mgKOH/g. TBN (mgKOH/g) test method; JIS K-201-5.2-2 (HCl), ASTM D4739 (HCl).

Engine Oil Viscosity

Select the appropriate engine oil viscosity based on the ambient temperature and use the SAE service grade viscosity chart in **Figure 3**.

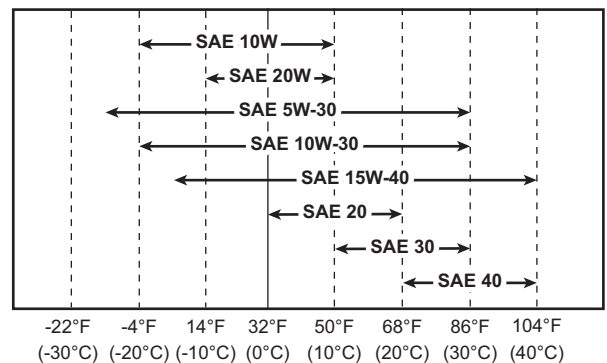

075177-00X

Figure 3

BEFORE YOU OPERATE

Checking Engine Oil

1. Make sure engine is level.
2. Remove dipstick (1, **Figure 4**) and wipe with clean cloth.
3. Fully reinsert dipstick.
4. Remove dipstick. The oil level should be between upper (2, **Figure 4**) and lower (3, **Figure 4**) lines on the dipstick.
5. Fully reinsert dipstick.

Adding Engine Oil

1. Make sure engine is level.
2. Remove oil cap (4, **Figure 4**).
3. Add indicated amount of engine oil at the top or side engine oil filler port (5, **Figure 4**).
4. Wait three minutes and check oil level.
5. Add more oil if necessary.
6. Reinstall oil cap (4, **Figure 4**) and hand-tighten. Over-tightening may damage the cap.

CAUTION

To refuel the engine oil, refuel slowly after removing the dipstick and both caps. If you refuel rapidly, the oil intrusion to the intake occurs through the PCV valve of the valve cover. It will result in an oil hammer at engine start, which may cause damage to the engine.

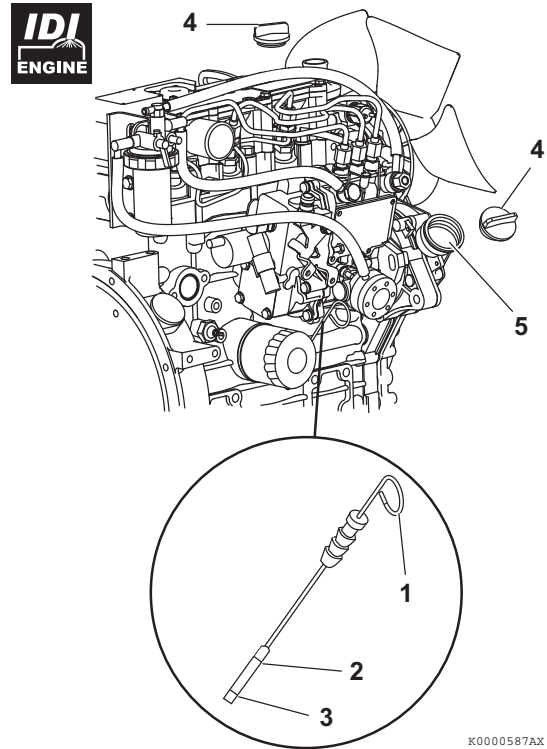

K0000597AX

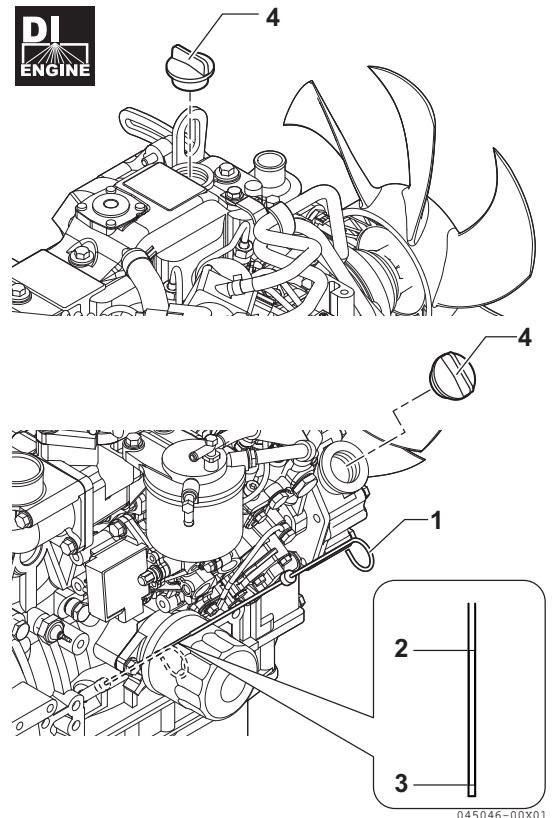

045046-00X01

Figure 4

Engine Oil Capacity (Typical)

These are the engine oil capacities associated with a “Deep Standard” oil pan. Oil capacity will vary dependent upon which optional oil pan is used. Refer to the operation manual provided by the driven machine manufacturer for the actual engine oil capacity of your machine.

The following are the engine oil capacities for various YANMAR TNM and TNV engines.

 Engine oil capacity (typical)	
Engine model	Dipstick upper limit/lower limit
3TNM74F	3.1 / 1.7 qt (2.9 / 1.6 L)
3TNV74F	3.0 / 1.6 qt (2.8 / 1.5 L)
3TNV76F, 3TNV80F-Z	3.6 / 1.9 qt (3.4 / 1.8 L)
3TNV80F, 3TNV80FT	3.6 / 1.9 qt (3.4 / 1.8 L)

 Engine oil capacity (typical)	
Engine model	Dipstick upper limit/lower limit
3TNV88F	7.1 / 4.1 qt (6.7 / 3.9 L)

ENGINE COOLANT

⚠ DANGER

Scald Hazard!



- Never remove the radiator cap if the engine is hot. Steam and hot engine coolant will spurt out and seriously burn you. Allow the engine to cool down before you attempt to remove the radiator cap.
- Tighten the radiator cap securely after you check the radiator. Steam can spurt out during engine operation if the cap is loose.
- Always check the level of the engine coolant by observing the reserve tank.
- Failure to comply will result in death or serious injury.

⚠ WARNING

Burn Hazard!



- Wait until the engine cools before you drain the engine coolant. Hot engine coolant may splash and burn you.
- Failure to comply could result in death or serious injury.

⚠ CAUTION

Engine Coolant Hazard!

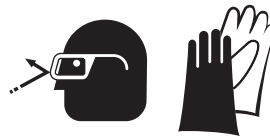

- Wear eye protection and rubber gloves when you handle long life or extended life engine coolant. If contact with the eyes or skin should occur, flush eyes and wash immediately with clean water.
- Failure to comply may result in minor or moderate injury.

NOTICE

- Only use the engine coolant specified. Other engine coolants may affect warranty coverage, cause an internal buildup of rust and scale and/or shorten engine life.
- Prevent dirt and debris from contaminating the engine coolant. Carefully clean the radiator cap and the surrounding area before you remove the cap.
- Never mix different types of engine coolants. This may adversely affect the properties of the engine coolant.

Engine Coolant Specifications

Use a Long Life Coolant (LLC) or an Extended Life Coolant (ELC) that meets or exceeds the following guidelines and specifications.

- ASTM D6210, D4985 (US)
- JIS K-2234 (Japan)
- SAE J814C, J1941, J1034 or J2036 (International)

Alternative engine coolant

If an Extended or Long Life Coolant is not available, alternatively, you may use an ethylene glycol or propylene glycol based conventional coolant (green).

NOTICE

- Always use a mix of coolant and water. Never use water only.
- Mix coolant and water per the mixing instructions on the coolant container.
- Water quality is important to coolant performance. YANMAR recommends that soft, distilled or demineralized water be used to mix with coolants.
- Never mix extended or long life coolants and conventional (green) coolants.
- Never mix different types and/or colors of extended life coolants.
- Replace the coolant every 2000 engine hours or 2 years.

Filling Radiator with Engine Coolant

Fill the radiator and reserve tank as follows. This procedure is for filling the radiator for the first time or refilling it after it is flushed. Note that a typical radiator is illustrated.

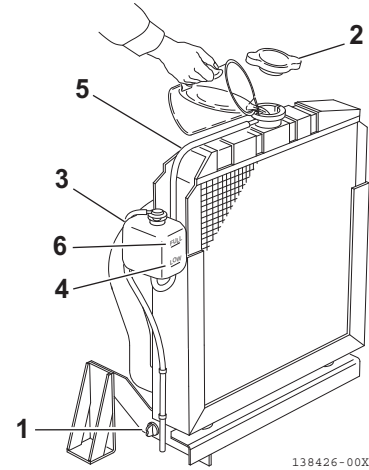

Figure 5

1. Check to be sure the radiator drain plug is installed and tightened or the drain valve (1, **Figure 5**) is closed. Also make sure the coolant drain plug (1, **Figure 6**) in the cylinder block is closed.

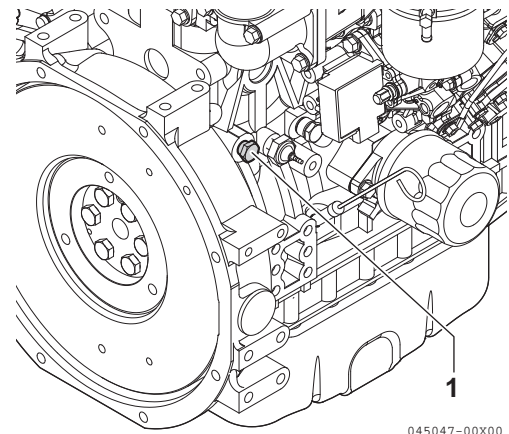

Figure 6

BEFORE YOU OPERATE

- Remove the radiator cap (2, **Figure 5**) by turning it counterclockwise about 1/3 of a turn.
- Pour the engine coolant slowly into the radiator until it is even with the lip of the engine coolant filler port. Make sure that air bubbles do not develop as you fill the radiator.
- Reinstall the radiator cap (2, **Figure 5**). Align the tabs on the back side of the radiator cap with the notches on the engine coolant filler port. Press down and turn the cap clockwise about 1/3 of a turn.
- Remove the cap of the reserve tank (3, **Figure 5**), and fill it to the LOW (COLD) mark (4, **Figure 5**) with engine coolant. Reinstall the cap.
- Check the hose (5, **Figure 5**) that connects the reserve tank (3, **Figure 5**) to the radiator. Be sure it is securely connected and there are no cracks or damage. If the hose is damaged, engine coolant will leak out instead of going into the reserve tank.
- Run the engine until it reaches operating temperature. Check the level of engine coolant in the reserve tank. When the engine is running and the engine coolant is at normal temperature, the coolant level in the reserve tank should be at or near the FULL (HOT) mark (6, **Figure 5**). If the coolant is not at the FULL (HOT) mark, add coolant to the reserve tank to bring the coolant level to the FULL (HOT) mark.

Daily Check of the Cooling System

- Check the level of engine coolant in the reserve tank. When the engine is cold, the coolant level in the tank should be at or slightly above the LOW (COLD) mark (4, **Figure 5**) on the coolant reserve tank.

If the coolant level is at the FULL (HOT) mark (6, **Figure 5**) when the engine is cold, the coolant will expand when it becomes hot and possibly spray out of the overflow hose.
- Add additional engine coolant to the reserve tank if necessary.
- Check the radiator hoses for cracks, abrasions, cuts or other damage. Replace as necessary.

Engine Coolant Capacity (Typical)

Capacities listed are for the engine only without a radiator. Refer to the operation manual provided by the driven machine manufacturer for actual engine coolant capacity on your machine.

The following are the engine coolant capacities for various YANMAR TNV engines.

 Engine coolant capacity (typical)	
Engine model	Engine coolant capacity
3TNM74F	1.1 qt (1.0 L)
3TNV74F	1.0 qt (0.9 L)
3TNV76F	1.0 qt (0.9 L)
3TNV80F, 3TNV80FT	1.0 qt (0.9 L)

 Engine coolant capacity (typical)	
Engine model	Engine coolant capacity
3TNV88F	2.1 qt (2.0 L)

DAILY CHECKS

Before you begin any job, make sure the YANMAR TNV engine is in good operating condition. Make sure you check the following items before you start your shift and have any repairs completed before you start work.

WARNING

High-Pressure Hazard!



- If fuel is spraying out or leaking from broken fuel system such as high-pressure fuel injection lines, it may be in high-pressure. Avoid skin contact. High-pressure fuel can penetrate your skin and result in serious injury. If you are exposed to high-pressure fuel spray, obtain prompt medical treatment.

- Have your YANMAR dealer or distributor repair the damage.
- Failure to comply could result in death or serious injury.

NOTICE

Make it a habit to perform daily checks. See *Daily Checks in the Before You Operate Section of this manual*.

Periodic maintenance prevents unexpected downtime, reduces the number of accidents due to poor machine performance and helps extend the life of the engine.

Visual Checks

1. Check for engine oil leaks.
2. Check for fuel leaks.
3. Check for engine coolant leaks.
4. Check for damaged or missing parts.
5. Check for loose, missing or damaged fasteners.

6. Check the electrical harnesses for cracks, abrasions, and damaged or corroded connectors.
7. Check hoses for cracks, abrasions, and damaged, loose or corroded clamps.
8. Check and clean radiator fins as necessary. See *Check and clean radiator fins on page 88*.
9. Check the water separator for presence of water and contaminants. If you find any water or contaminants, drain the water separator. See *Drain water separator on page 82*. If you have to drain the water separator frequently, drain the fuel tank and check for the presence of water in your fuel supply. See *Drain fuel tank on page 85*.

NOTICE

If any problem is noted during the visual check, the necessary corrective action should be taken before you operate the engine.

Check Diesel Fuel, Engine Oil and Engine Coolant Levels

Follow the procedures in *Diesel Fuel on page 54*, *Engine Oil on page 59* and *Engine Coolant on page 62* to check these levels.

Check Engine Speed Control

Check the engine speed control for smooth operation, adjust and lubricate or clean as necessary. See *Check and adjust the governor lever and engine speed control (except electronic controlled engines) on page 89*.

Check Operator's Console

Before you operate the engine you should make sure that all of the indicators are functioning properly.

Check Indicators

YANMAR TNM and TNV engines are available with various operator's consoles. In the below Figures, three types of typical operator's console including the one for electronic controlled engines are shown as examples.

BEFORE YOU OPERATE

1 HEAT

Figure 7 shows a typical indicator arrangement on the operator's console. With the specification of standard glow (preheat), as you turn the key switch to the HEAT position, the HEAT indicator is turned on for 4 seconds, showing that the glow plugs are energized. When the indicator goes off, turn the key switch to START position and start the engine. In the case of 3TNV88F (DI), the indicator goes off after 15 seconds.

Figure 8 shows an indicator arrangement with the specification for ON-glow. As you turn the key switch to ON position, the HEAT indicator is turned on for 4 seconds. When the indicator goes off, turn the key switch to the START position and start the engine. In the case of 3TNV88F (DI), the indicator goes off after 15 seconds.

Figure 9 shows an operator's console of an electronic controlled engine. The electronic controlled engine has an ON-glow specification. Depending on the water temperature, the heat indicator will turn on for 15 seconds at the longest, and preheats the glow plugs. When the indicator goes off, turn the key switch to the START position and start the engine.

2 Battery charge

Stays on until the engine is running and the alternator is supplying charging current. This indicator does not indicate whether the battery is discharged.

3 Engine oil pressure

Stays on until the engine is running and the oil pressure is within normal limits.

4 Engine coolant temperature

Stays on momentarily. Comes back on if engine overheats.

5 Auxiliary

Stays on momentarily. Used for special applications.

Here is a summary of how these indicators function. The table shows what happens when you turn the key in a certain direction (e.g., OFF to ON).

6 Engine failure lamp (optional)

In the case of electronic controlled engine shown in **Figure 9**, illuminates for approx. 2 sec. when the key switch is turned to ON, and stays off while the engine is running. If a fault occurs in the Eco-governor system or during energization of the ECU, this indicator will flash in a certain pattern to indicate what fault has occurred. See the troubleshooting section for details.

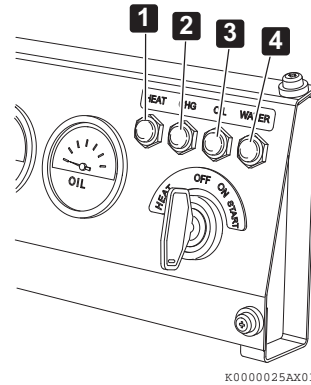

Figure 7

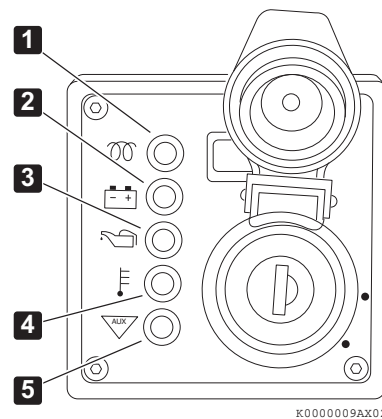
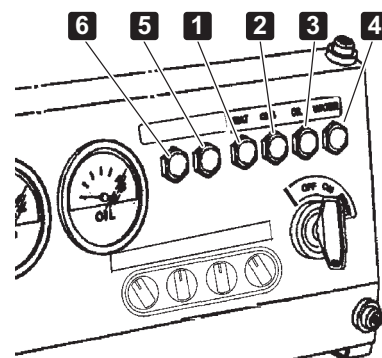

Figure 8



DI ENGINE 3TNV88F-E

Figure 9

Note: **Figure 9** Typical operator's console.

Indicator		OFF to HEAT	OFF to ON	ON to OFF	
HEAT (1, Figure 8) (1, Figure 7) (1, Figure 9)	ON-glow type	Glow	NA	IDI (3TNM74F, 3TNV74F, 3TNV80F) turns off after indicating for 4 seconds. DI (3TNV88F-U) turns off after indicating for 15 seconds. Note that, for electronic control type engines (3TNV88F-E), the indicators are controlled from 1 to 15 seconds depending on the temperature of cooling water.	OFF
	HEAT position available on key switch	Glow	IDI (3TNM74F, 3TNV74F, 3TNV80F) turns off after indicating for 4 seconds. DI (3TNV88F) turns off after indicating for 15 seconds.	OFF	OFF
Battery charge (2, Figure 8) (2, Figure 7) (2, Figure 9)		NA	ON	OFF (Stays on until alternator is supplying charging current. Remains on if there is a problem in the charging system. This indicator does not indicate whether the battery is discharged.)	
Engine oil pressure (3, Figure 8) (3, Figure 7) (3, Figure 9)		NA	ON	OFF (Stays on until oil pressure reaches normal operating pressure. Remains on, or comes back on, if there is a problem in the lubrication system.)	
Engine coolant temperature (4, Figure 8) (4, Figure 7) (4, Figure 9)		NA	ON	OFF (Stays on momentarily. Comes back on if there is a problem in the cooling system.)	
Auxiliary (5, Figure 8) (5, Figure 9)		NA	ON	OFF	
Engine failure lamp (optional) (6, Figure 9) 3TNV88F		NA	Lights for 2 sec. only.	OFF (Flashes or intermittently lights if a fault occurs in the ECU or Eco-governor.)	

This Page Intentionally Left Blank

ENGINE OPERATION

This section of the Operation Manual describes the procedures for starting the engine, checking engine performance during operation, and shutting the engine down.

ENGINE OPERATION

STARTING ENGINE

Use the following procedure to start the engine. Note that two typical operator's consoles are shown for illustrative purposes only.

1. Make sure you follow the procedures stated in the *Daily Checks* on page 65.
2. Before first starting electronic controlled engines (3TNV88F-E, 3TNV80FT, 3TNV80F-Z):
The ECU of the electronic controlled engines shown above needs to be initialized at initial power up. When the engine failure lamp comes on at initial power up, the ECU has finished initialization. Then always turn the key switch to the OFF position once before starting the engine. (The ECU has usually been initialized before the driven machine is delivered). From the second power up, make sure the engine failure lamp is on for 2 sec. when turning the key switch to the ON position.
3. Make sure the water separator fuel valve (1, **Figure 1**) is in the ON position (2, **Figure 1**).

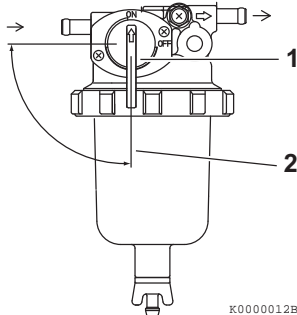
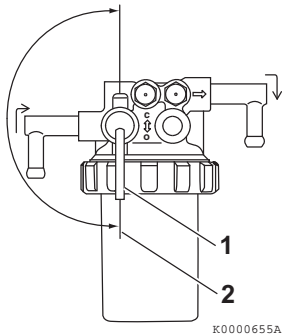

Figure 1

4. Set the transmission (if equipped) in the NEUTRAL position.
5. Disengage the PTO (if equipped).
6. Set the engine speed control to the mid-position.

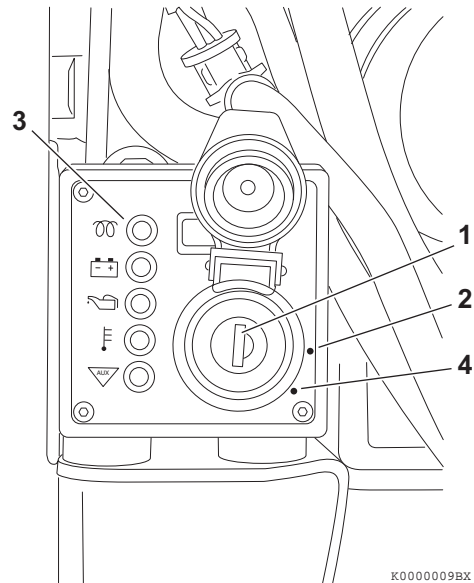

Figure 2

NOTICE

Never use an engine starting aid such as ether. Engine damage will result.

7. Insert the key into the key switch (1, **Figure 2**) or (1, **Figure 3**).

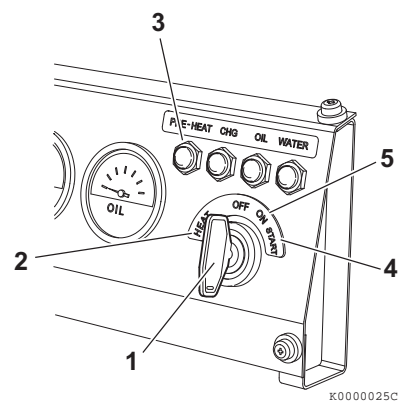

Figure 3

8. Turn the key to the ON position (2, **Figure 2**) or the HEAT position (2, **Figure 3**). The pre-heat indicator (3, **Figure 2**) flashes for several seconds and then goes out. After the pre-heat indicator goes out you can start the engine.

Note: The glow plugs are used to assist starting in cold weather conditions. If you are operating your engine in normal or warm weather conditions, you may bypass the Pre-Heat/Heat functions and go directly to Start.

NOTICE

Never hold the key in the START position for longer than 15 seconds or the starter motor will overheat.

9. Turn the key clockwise to the START position (4, **Figure 2**) or (4, **Figure 3**). Release the key as soon as the engine starts. It will return to the ON position (2, **Figure 2**) or (5, **Figure 3**).

Note: The starter of electronic controlled engines (3TNV88F-E, 3TNV80FT, 3TNV80F-Z) will start with a delay of approx. 0.5 sec. after the key switch has been turned to the ON position. This is because the ECU self-diagnostics has run and is not a failure.

10. If the engine fails to start:

- 1- Wait until the engine comes to a complete stop before you attempt to start it again. Engaging the starter while the engine is still rotating will result in damage to the starter and flywheel.

Note: Some key switches are equipped with an interlock that will not allow you to re-engage the starter without first turning the key to the OFF position.

- 2- Wait at least 30 seconds before you attempt to start the engine again. This procedure will allow the battery voltage to recover and prevent damage to the starter motor due to the low battery voltage.

⚠ WARNING

Sudden Movement Hazard!

- Engaging the transmission or PTO at an elevated engine speed could result in unexpected movement of the equipment.
- Failure to comply could result in death or serious injury.

Cold start device for electronic controlled engines



3TNV88F-E

- The direct injection 3TNV88F-E is equipped with a cold start device (CSD) for assisting engine start-up at cold temperatures.
- If the engine cooling system temperature is below 5 °C, the CSD automatically advances the fuel injection timing and slightly increases the fuel injection volume based on signals from the ECU.
- The engine idle speed is slightly elevated for approximately the first 5 minutes of operation.
- When the CSD is activated, you may notice a slight increase in the amount of exhaust smoke. This is normal.
- Never engage the transmission or PTO while the CSD is operating. It could result in unexpected movement of the machine.



3TNV80FT, 3TNV80F-Z

- The indirect injection 3TNV80FT is not equipped with a CSD. The actuator of the Eco-governor controls the fuel injection volume, and increases it based on signals from the ECU during engine start-up at cold temperatures.
- As with direct injection models, the engine idle speed is slightly elevated for approximately the first 5 minutes of operation. Never engage the transmission or PTO during the first 5 minutes of operation. It could result in unexpected movement of the machine.

ENGINE OPERATION

High-Altitude Injection Control Device

3TNM74F, 3TNV74F, 3TNV76F, 3TNV80F

This series has a high-altitude injection control device installed. It suppresses black smoke when operating at high altitudes and at the same time aims to control particulate matter.

The device consists of an output control solenoid that is attached to the fuel injection pump and a solenoid driver (with an atmospheric pressure sensor) that is assembled on the implement side. The output control solenoid actuates at engine start. (It does not actuate during engine operation.) At engine start, the starter operates and the engine starts running. 4 seconds after the starter turns off, the solenoid driver measures the atmospheric pressure and determines whether to actuate the solenoid. (The solenoid is energized during normal operation, but it is turned off during the start of the control device.) If at this time the atmospheric pressure sensor determines that the altitude is 2624 ft (800 m) or more, the control device operates. It reduces the fuel injection amount and thus controls the occurrence of black smoke. Because of this reduction in the injection amount, the output decreases. At 5500 ft (1676 m), the decrease in output (i.e. torque) is 20% of the maximum at low altitudes. Therefore, only apply medium to low load when operating at high altitudes.

NOTICE

The injection control device does not actuate during engine operation. (Switch operation is not performed.) Therefore, when the control device is not yet operating and the machine is moved to a high altitude during operation, or when the control device is already operating and the machine is moved to a low altitude, turn the key switch to OFF (engine stop). This resets the control device. After re-starting the engine, the necessity for injection control is again determined.

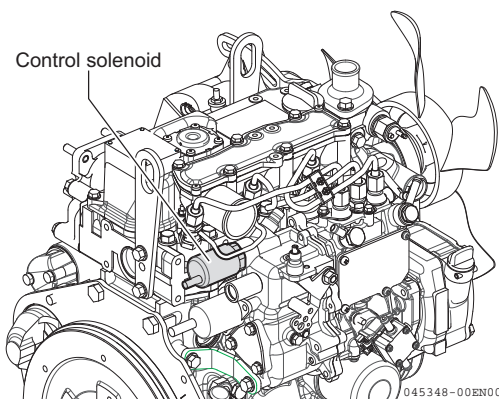

Figure 4

3TNV88F-E, 3TNV80FT

The ECU controls fuel injection volume of the electronic controlled engines according to the altitude.

CHECKING THE ENGINE DURING OPERATION

⚠ WARNING

High-Pressure Hazard!



- While the engine is running or right after the engine has stopped, there is still high-pressure fuel left in the fuel piping system. When you need to disassemble the fuel system, wait for 10 to 15 minutes after stopping the engine.
- If fuel is spraying out or leaking from broken fuel system such as high-pressure fuel injection lines, it may be in high-pressure. Avoid skin contact. High-pressure fuel can penetrate your skin and result in serious injury. If you are exposed to high-pressure fuel spray, obtain prompt medical treatment.
- Disassembling or repairing the fuel system shall be done by professionals such as the authorized YANMAR distributor or dealer.
- Failure to comply could result in death or serious injury.

NOTICE

Make sure the engine is installed on a level surface. If a continuously running engine is installed at an angle greater than (IDI = 25°, DI = 30°) in any direction or if an engine runs for short periods of time (less than three minutes) at an angle greater than (IDI = 30°, DI = 35°) in any direction, engine oil may enter the combustion chamber causing excessive engine speed and white exhaust smoke. This may cause serious engine damage.

NOTICE

New engine break-in:

- On the initial engine start-up, allow the engine to idle for approximately 15 minutes while you check for proper engine oil pressure, diesel fuel leaks, engine oil leaks, coolant leaks, and for proper operation of the indicators and/or gauges.
- During the first hour of operation, vary the engine speed and the load on the engine. Short periods of maximum engine speed and load are desirable. Avoid prolonged operation at minimum or maximum engine speeds and loads for the next four to five hours.
- During the break-in period, carefully observe the engine oil pressure and engine temperature.
- During the break-in period, check the engine oil and coolant levels frequently.

NOTICE

Never engage the starter motor while the engine is running. This may damage the starter motor pinion and/or ring gear.

1. While the engine is running, check the gauges for normal indications. The gauges shown in **Figure 6** and **Figure 5** are provided for illustrative purposes only.

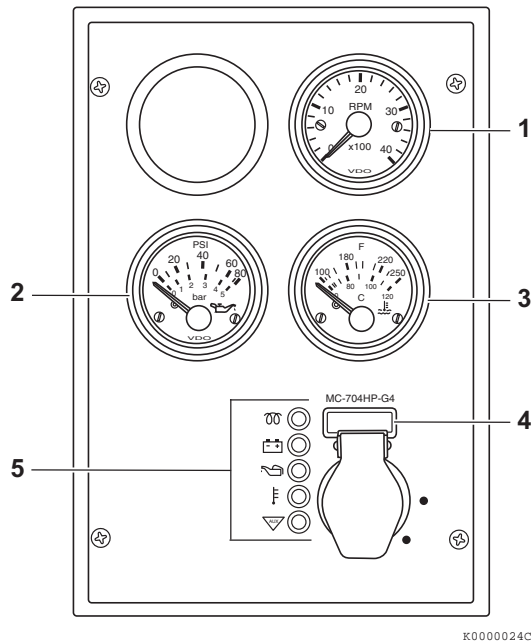

Figure 5

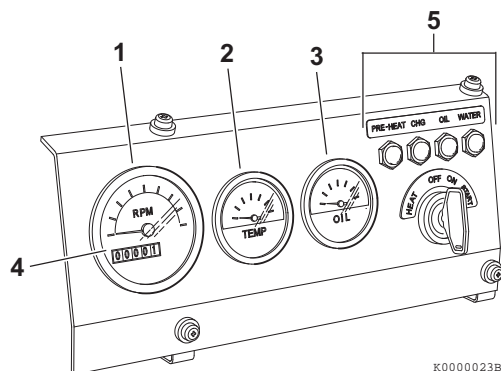

Figure 6

- **Tachometer**(1, **Figure 5**) or (1, **Figure 6**) - Make sure the engine speed is within normal limits.

- **Engine oil pressure** (2, **Figure 5**) or (3, **Figure 6**) - Make sure the engine oil pressure is within normal limits. See *Principal Engine Specifications* on page 119.
 - **Engine coolant temperature** (3, **Figure 5**) or (2, **Figure 6**) - Make sure the engine coolant temperature is within normal limits.
 - **Hour meter** - The hour meter display (4, **Figure 5**) or (4, **Figure 6**) shows the total number of hours the engine has run. This is useful for planning periodic maintenance operations. See *Periodic Maintenance Schedule* on page 78.
 - If any of the gauges shows an out of normal limits condition, shut down the engine and have the necessary repairs performed.
2. After the engine has reached operating temperature, all of the indicators (5, **Figure 5**) or (5, **Figure 6**) should be off. If any of the indicators are on, shut down the engine and have the necessary repairs performed.
 3. Check for any fuel, engine coolant or engine oil leaks. If any leaks are found shut down the engine and have the necessary repairs performed.
 4. Check for abnormal sounds or vibration. In some applications the engine and its mounting may start to resonate and cause unusual vibrations at certain engine speeds. Avoid running the engine at these speeds. If the abnormal sounds or vibration cannot be resolved, shut down the engine and have the necessary repairs performed. Contact your authorized YANMAR industrial engine dealer or distributor.
 5. Check for white or black smoke from the exhaust system. A small amount of white exhaust smoke is normal on start-up of a cold engine. Black exhaust smoke could mean the engine is overloaded or is being over-fueled. If either of these conditions persists, contact your authorized YANMAR industrial engine dealer or distributor.
 6. Check the fuel level during operation. If the fuel level runs low, stop the engine and refuel.

ENGINE OPERATION

Adjust Engine Speed

NOTICE

New engine break-in:

- On the initial engine start-up, allow the engine to idle for approximately 15 minutes while you check for proper engine oil pressure, diesel fuel leaks, engine oil leaks, coolant leaks, and for proper operation of the indicators and/or gauges.
- During the first hour of operation, vary the engine speed and the load on the engine. Short periods of maximum engine speed and load are desirable. Avoid prolonged operation at minimum or maximum engine speeds and loads for the next four to five hours.
- During the break-in period, carefully observe the engine oil pressure and engine temperature.
- During the break-in period, check the engine oil and coolant levels frequently.

Use the engine speed control to adjust the engine speed for the task that will be performed.

SHUTTING DOWN THE ENGINE

NOTICE

For maximum engine life, YANMAR recommends that when shutting the engine down, you allow the engine to idle, without load, for five minutes. This will allow the engine components that operate at high temperatures, such as the turbocharger (if equipped) and exhaust system, to cool slightly before the engine itself is shut down.

Follow these steps to shut down the engine:

1. Disengage the PTO and/or set the transmission to NEUTRAL (if equipped).
2. Set the engine speed control to its lowest setting.

3. Run the engine at low idle speed for at least five minutes before you shut it down.

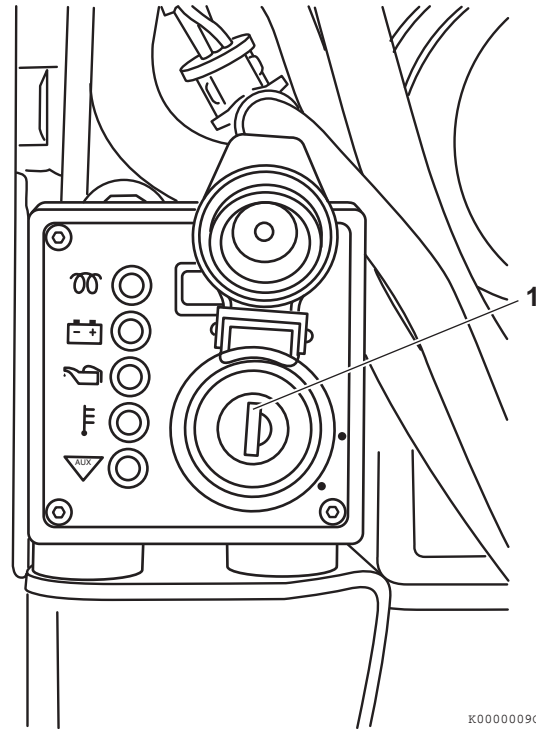

Figure 7

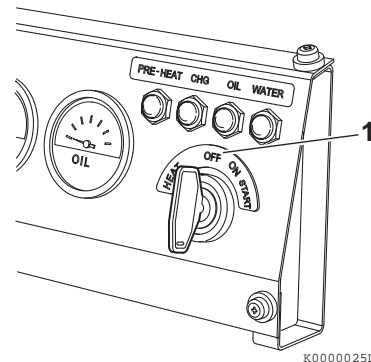

Figure 8

4. Turn the key to the OFF position (1, **Figure 7**) or (1, **Figure 8**) and remove it from the key switch.
5. If the engine will not be used for six months or longer, follow the additional instructions in *Long-Term Storage* on page 113.

PERIODIC MAINTENANCE

This section of the Operation Manual describes the procedures for proper care and maintenance of the engine.

PRECAUTIONS

The Importance of Periodic Maintenance

Engine deterioration and wear occurs in proportion to length of time the engine has been in service and the conditions the engine is subject to during operation. Periodic maintenance prevents unexpected downtime, reduces the number of accidents due to poor machine performance and helps extend the life of the engine.

Performing Periodic Maintenance

WARNING

Exhaust Hazard!



- **Never operate the engine in an enclosed area such as a garage, tunnel, underground room, manhole or ship's hold without proper ventilation.**
- **Never block windows, vents, or other means of ventilation if the engine is operating in an enclosed area. All internal combustion engines create carbon monoxide gas during operation. Accumulation of this gas within an enclosure could cause illness or even death.**
- **Make sure that all connections are tightened to specifications after repair is made to the exhaust system.**
- **Failure to comply could result in death or serious injury.**

Perform periodic maintenance procedures in an open, level area free from traffic. If possible, perform the procedures indoors to prevent environmental conditions, such as rain, wind, or snow, from damaging the machine.

The Importance of Daily Checks

Periodic Maintenance Schedules assume that the daily checks are performed on a regular basis. Make it a habit of performing daily checks before the start of each shift. See *Daily Checks on page 65*.

Keep a Log of Engine Hours and Daily Checks

Keep a log of the number of hours the engine is run each day and a log of the daily checks performed. Also note the date, type of repair (e.g., replaced alternator), and parts needed for any service needed between the periodic maintenance intervals. Periodic maintenance intervals are every 50, 250, 500, 1000, 1500, 2000 and 3000 engine hours. Failure to perform periodic maintenance will shorten the life of the engine.

YANMAR Replacement Parts

YANMAR recommends that you use genuine YANMAR parts when replacement parts are needed. Genuine replacement parts help ensure long engine life.

Tools Required

Before you start any periodic maintenance procedure make sure you have the tools you need to perform all of the required tasks.

Ask Your Authorized YANMAR Industrial Engine Dealer or Distributor For Help

Our professional service technicians have the expertise and skills to help you with any maintenance or service related procedures you need help with.

Required EPA/ARB Maintenance USA Only

To maintain optimum engine performance and compliance with the Environmental Protection Agency (EPA) Regulations Non-Road Engines and the California Air Resources Board (ARB, California), it is essential that you follow the *Periodic Maintenance Schedule on page 78* and *Periodic Maintenance Procedures on page 80*.

EPA/ARB Installation Requirements USA Only

The following are the installation requirements for the EPA/ARB. Unless these requirements are met, the exhaust gas emissions will not be within the limits specified by the EPA and ARB.

Therefore, periodically perform the maintenance and cleaning of air cleaner and muffler.

Upper limit of intake negative pressure and exhaust pressure for use in highlands

Altitude used	Upper limit at altitude used	
	Intake negative pressure (kPa)	Exhaust pressure (kPa)
0 to 800 m (0 to 2624 ft)	6.23	10.3
800 to 1676 m (2624 to 5500 ft)	4.0	8.1

Tightening Fasteners

Use the correct amount of torque when you tighten fasteners on the machine. Applying excessive torque may damage the fastener or component and not enough torque may cause a leak or component failure.

NOTICE

The tightening torque in the *Standard Torque Chart in the Periodic Maintenance Section of this manual* should be applied only to the bolts with a “7” head. (JIS strength classification: 7T)

- For 4T bolts and locknuts, apply 60% of the torque listed in the table.
- If aluminum alloy is contained in the parts to be tightened, apply 80% of the torque listed in the table.



PERIODIC MAINTENANCE

STANDARD TORQUE CHART

Thread size x pitch	mm	M6 x 1.0	M8 x 1.25	M10 x 1.5	M12 x 1.75	M14 x 1.5	M16 x 1.5
Tightening torque	in.-lb	96.0 ± 9.0	–	–	–	–	–
	ft-lb	–	19.0 ± 2.0	36.0 ± 4.0	65.0 ± 7.0	101.0 ± 7.0	167.0 ± 7.0
	N·m	10.8 ± 1.0	25.5 ± 2.9	49.0 ± 4.9	88.3 ± 9.8	137.0 ± 9.8	226.0 ± 9.8
	kgf·m	1.1 ± 0.1	2.6 ± 0.3	5.0 ± 0.5	9.0 ± 1.0	14.0 ± 1.5	23.0 ± 2.0

Note: Torque values shown in this manual are for clean, non-lubricated fasteners unless otherwise specified.

PERIODIC MAINTENANCE SCHEDULE

Daily and periodic maintenance is important to keep the engine in good operating condition. The following is a summary of maintenance items by periodic maintenance intervals. Periodic maintenance intervals vary depending on engine application, loads, diesel fuel and engine oil used and are hard to establish definitively. The following should be treated only as a general guideline.

NOTICE

Establish a periodic maintenance plan according to the engine application and make sure you perform the required periodic maintenance at intervals indicated. Failure to follow these guidelines will impair the engine's safety and performance characteristics, shorten the engine's life and may affect the warranty coverage on your engine. See *YANMAR Limited Warranty in the Warranty Section of this manual*.

Check the oil level daily. If it is below the lower limit of the dipstick add the new oil to keep the oil level between upper and lower mark, even if it is remaining the change interval.

Consult your authorized YANMAR industrial engine dealer or distributor for assistance when checking items marked with a ●.

Periodic Maintenance Chart

○: Check ◇: Replace ●: Contact your authorized YANMAR industrial engine dealer or distributor

System	Check item	Daily	Periodic maintenance interval						
			Every 50 hours	Every 250 hours	Every 500 hours	Every 1000 hours	Every 1500 hours	Every 2000 hours	Every 3000 hours
Cooling system	Check and refill engine coolant	○							
	Check and clean radiator fins			○					
	Check and adjust cooling fan V-belt		○ 1st time	○ 2nd and after					
	Change coolant							◇ or every 2 years which-ever comes first	
Cylinder head	Check and adjust intake/exhaust valve clearance					●			

PERIODIC MAINTENANCE

○: Check ◇: Replace ●: Contact your authorized YANMAR industrial engine dealer or distributor

System	Check item	Daily	Periodic maintenance interval						
			Every 50 hours	Every 250 hours	Every 500 hours	Every 1000 hours	Every 1500 hours	Every 2000 hours	Every 3000 hours
Electrical equipment	Check indicators	○							
	Inspect ECU and related sensors and actuators (3TNV80FT, 3TNV88F-E)								●
	Check battery and recharge		○						
Engine oil	Check engine oil level	○							
	Drain and fill engine oil				◇*1	◇ or every 1 year*2			
	Replace engine oil filter								
Engine speed control	Check and adjust governor lever and engine speed control	○		○					
Emission control warranty	Inspect, clean and test fuel injection nozzle, if necessary							● Cleaning only	●
	Inspect turbocharger (blower wash as necessary) (3TNV80FT)								●
	 Inspect, clean and test EGR valve (3TNV88F-E)								●
	Inspect crankcase breather system							●	
Fuel	Check and refill fuel tank level	○							
	Drain fuel tank			○					
	Drain water separator		○						
	Check water separator	○							
	Clean water separator				○				
	Replace fuel filter				◇				
Hoses	Check and replace fuel hoses and engine coolant hoses							◇ or every 2 years	
Intake and exhaust	Clean or replace air cleaner element			○*3	◇*3				
Complete engine	Overall visual check daily	○							

*1: 3TNV74F, 3TNV80F and 3TNM74F

*2: 3TNV88F (Differ depending on the application or engine oil capacity.)

If the engine is equipped with a shallow type oil sump, the maintenance interval should be every 250 hours regardless of the implement.

*3: If equipment has a warning system for the maintenance of air cleaner, the maintenance will be conducted depending on the air cleaner condition after such alarm is raised. If not so, maintenance will be conducted as specified in Table.

Note: These procedures are considered normal maintenance and are performed at the owner's expense.

PERIODIC MAINTENANCE PROCEDURES

After Initial 50 Hours of Operation

Perform the following maintenance after the initial 50 hours of operation.

- Check and adjust cooling fan V-belt

⚠ WARNING

Sudden Movement Hazard!

- Engaging the transmission or PTO at an elevated engine speed could result in unexpected movement of the equipment.
- Failure to comply could result in death or serious injury.

■ Check and adjust cooling fan V-belt

The V-belt will slip if it does not have the proper tension. This will prevent the alternator from generating sufficient power. Also, the engine will overheat due to the engine coolant pump pulley slipping.

Check and adjust the V-belt tension (deflection) as follows:

1. Press the V-belt down with your thumb with a force of approximately 22 lb (98 N, 10 kgf) to check the deflection.

There are three positions to check for V-belt tension (A, B and C, **Figure 1**). You can check the tension at whichever position is the most accessible. The proper deflection of a used V-belt at each position is:

Used V-belt tension		
A	B	C
3/8 - 1/2 in. (10 - 14 mm)	1/4 - 3/8 in. (7 - 10 mm)	5/16 - 1/2 in. (9 - 13 mm)

Note: A "Used V-Belt" refers to a V-belt which has been used on a running engine for five minutes or more.

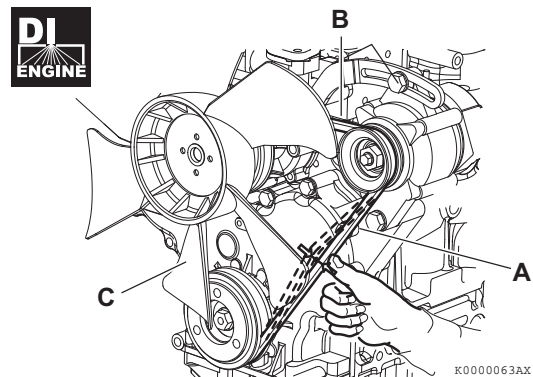
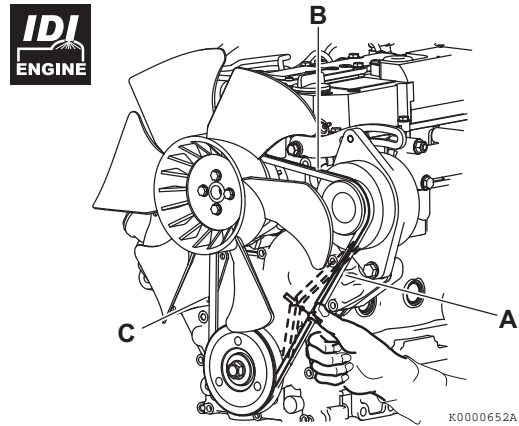
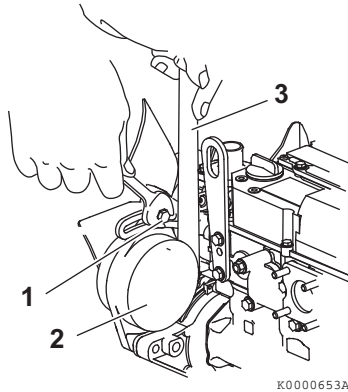
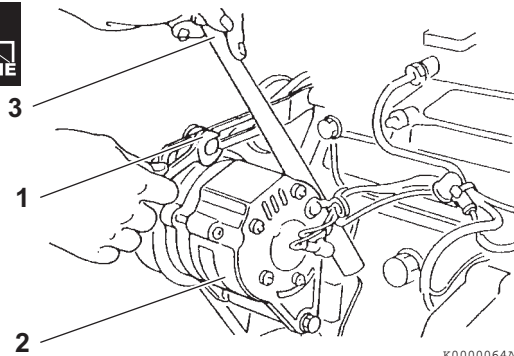

Figure 1

- If necessary, adjust the V-belt tension. Loosen the adjusting bolt (1, **Figure 2**) and related bolts and/or nuts, then move the alternator (2, **Figure 2**) with a pry bar (3, **Figure 2**) to tighten the V-belt to the desired tension. Then tighten the adjusting bolts and/or nuts.



K0000653A



K000064AX

Figure 2

- Tighten the V-belt to the proper tension. There must be clearance (1, **Figure 3**) between the V-belt and the bottom of the pulley groove. If there is no clearance (2, **Figure 3**) between the V-belt and the bottom of the pulley groove, replace the V-belt.

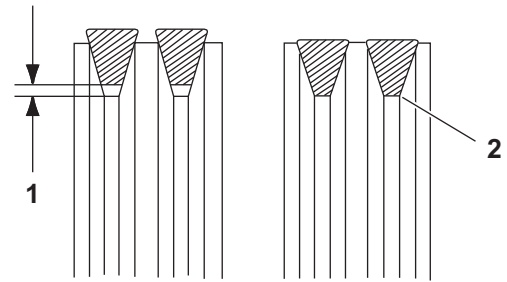

141437-00X

Figure 3

- Check the V-belt for cracks, oil or wear. If any of these conditions exist, replace the V-belt.
- Install the new V-belt. Refer to the table for proper tension.

New V-belt tension		
A	B	C
5/16 - 7/16 in. (8 - 12 mm)	3/16 - 5/16 in. (5 - 8 mm)	1/4 - 7/16 in. (7 - 11 mm)

- After adjusting, run the engine for 5 minutes or more. Check the tension again using the specifications for a used V-belt.

Used V-belt tension		
A	B	C
3/8 - 1/2 in. (10 - 14 mm)	1/4 - 3/8 in. (7 - 10 mm)	5/16 - 1/2 in. (9 - 13 mm)

PERIODIC MAINTENANCE

Every 50 Hours of Operation

After you complete the initial 50 hour maintenance procedures, perform the following procedures every 50 hours thereafter.

- Drain water separator
- Check battery and recharge

■ Drain water separator

DANGER

Fire and Explosion Hazard!



- Diesel fuel is flammable and explosive under certain conditions.

- When you remove any fuel system component to perform maintenance (such as changing the fuel filter) place an approved container under the opening to catch the fuel.
- Never use a shop rag to catch the fuel. Vapors from the rag are flammable and explosive.
- Wipe up any spills immediately.
- Wear eye protection. The fuel system is under pressure and fuel could spray out when you remove any fuel system component.
- Failure to comply will result in death or serious injury.

NOTICE



If no water drips when the water separator drain valve is opened, loosen the air vent screw on the top of the water separator by using a screwdriver to turn it counterclockwise 2 - 3 turns.

This may occur if the water separator is positioned higher than the fuel level in the fuel tank. After draining the water separator, be sure to tighten the air vent screw.

NOTICE



- Always be environmentally responsible.

- Follow the guidelines of the EPA or other governmental agencies for the proper disposal of hazardous materials such as engine oil, diesel fuel and engine coolant. Consult the local authorities or reclamation facility.
- Never dispose of hazardous materials irresponsibly by dumping them into a sewer, on the ground, or into ground water or waterways.
- Failure to follow these procedures may seriously harm the environment.

Drain the water separator whenever there are contaminants, such as water, collected in the bottom of the cup. Never wait until the scheduled periodic maintenance if contaminants are discovered.

The separator cup is made from semi-transparent material. In the cup is a red-colored float ring. The float ring will rise to the surface of the water to show how much needs to be drained. Also, some optional water separators are equipped with a sensor to detect the amount of contaminants. This sensor sends a signal to an indicator to alert the operator.



Drain the water separator as follows:

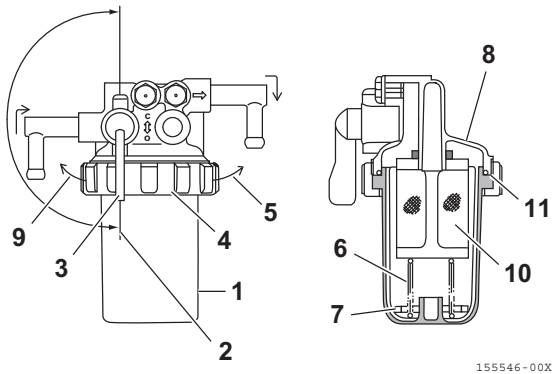

Figure 4

1. Position an approved container under the water separator (1, **Figure 4**) to collect the contaminants.
2. Close (2, **Figure 4**) the fuel valve (3, **Figure 4**).
3. Turn the retaining ring (4, **Figure 4**) to the left (9, **Figure 4**).
4. Carefully remove the cup (1, **Figure 4**). Remove the retaining spring (6, **Figure 4**) and float (7, **Figure 4**) from the cup. Pour the fuel into an approved container and dispose of waste properly. Hold the bottom of the cup with a shop towel to prevent the fuel from dripping. Wipe up any spills immediately.
5. Clean the inside of the cup.
6. Inspect the condition of the mesh filter (10, **Figure 4**). Clean the mesh filter if necessary.
7. Inspect the condition of the O-ring (11, **Figure 4**). Replace the O-ring if necessary.
8. Put the float (7, **Figure 4**) and retaining spring (6, **Figure 4**) inside the cup.
9. Reinstall the cup to the mounting flange (8, **Figure 4**) and turn the retaining ring (4, **Figure 4**) to the right (5, **Figure 4**) hand-tighten only.
10. Open the fuel valve (3, **Figure 4**).
11. Be sure to prime the diesel fuel system when you are done. See *Priming the Fuel System* on page 58.
12. Check for fuel leaks.



Drain the water separator as follows:

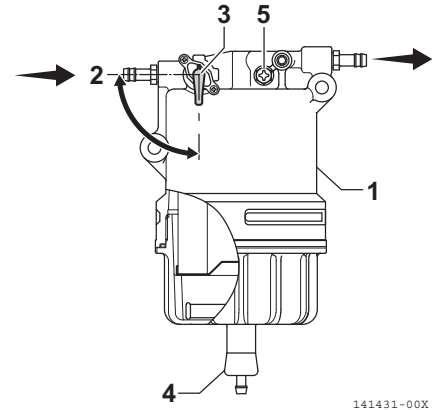

Figure 5

1. Position an approved container under the water separator (1, **Figure 5**) to collect water and contaminants drained from the water separator.
 2. Close (2, **Figure 5**) the fuel valve (3, **Figure 5**).
 3. Open the drain valve (4, **Figure 5**) at the bottom of the water separator. Drain any water collected inside. If no water comes out, loosen the air vent screw (5, **Figure 5**) at the top of the water separator by turning it counterclockwise 2 - 3 turns.
 4. If still no water comes out, open the fuel valve (3, **Figure 5**).
 5. After draining the water separator, hand-tighten the drain valve.
- | | |
|-------------------|--------------------------------|
| Tightening torque | 1 - 2 N·m
(0.1 - 0.2 kgf·m) |
|-------------------|--------------------------------|
6. Be sure to tighten the air vent screw if it is loosened.
 7. Open the fuel valve.
 8. Be sure to prime the diesel fuel system. See *Priming the Fuel System* on page 58.
 9. Check for fuel leaks.

PERIODIC MAINTENANCE

■ Check battery and recharge

⚠ DANGER

Explosion Hazard!



- Never short out the battery terminals, including when checking the remaining battery charge. This will result in a spark and may cause an explosion or fire. Use a hydrometer to check the remaining battery charge.
- If the electrolyte is frozen, slowly warm the battery before you recharge it.
- Failure to comply will result in death or serious injury.

⚠ WARNING

Burn Hazard!



- Batteries contain sulfuric acid. Never allow battery fluid to come in contact with clothing, skin or eyes. Severe burns could result. Always wear safety goggles and protective clothing when servicing the battery. If battery fluid contacts the eyes and/or skin, immediately flush the affected area with a large amount of clean water and obtain prompt medical treatment.
- Failure to comply could result in death or serious injury.

NOTICE



- Always be environmentally responsible.

- Follow the guidelines of the EPA or other governmental agencies for the proper disposal of hazardous materials such as engine oil, diesel fuel and engine coolant. Consult the local authorities or reclamation facility.
- Never dispose of hazardous materials irresponsibly by dumping them into a sewer, on the ground, or into ground water or waterways.
- Failure to follow these procedures may seriously harm the environment.

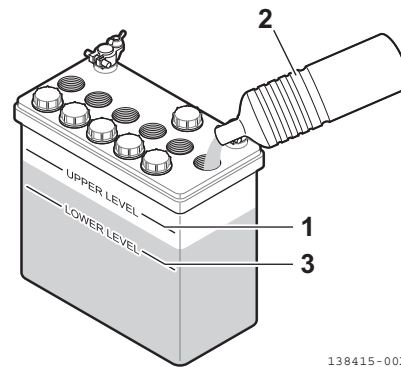

Figure 6

- When the amount of fluid nears the lower limit (3, **Figure 6**), fill with distilled water (2, **Figure 6**) so it is at the upper limit (1, **Figure 6**). If operation continues with insufficient battery fluid, the battery life is shortened, and the battery may overheat and explode. During the summer, check the fluid level more often than specified.

- If the engine cranking speed is so slow that the engine does not start, recharge the battery. Use a specialized battery charger to recharge the battery with a voltage of 8 volts or less. Charging the battery by booster even with a voltage of 8 volts or less will generate an abnormally high voltage and destroy electrical equipment. Further, in the electronic control engine 3TNV88F-E, when unavoidably using a rapid charger to recharge, do not insert and turn the starter key to ON position while the battery is being charged. Avoid using a charger equipped with a boost function (cell start support) to start the engine. The ECU may be damaged by applied excessive voltage.
- If the engine still will not start after charging, have your authorized YANMAR industrial engine dealer or distributor check the battery and the engine's starting system.
- If operating the machine where the ambient temperature could drop to -15 °C (5 °F) or less, remove the battery from the machine at the end of the day. Store the battery in a warm place until the next use. This will help start the engine easily at low ambient temperatures.

Every 250 Hours of Operation

Perform the following maintenance every 250 hours of operation.

- Drain fuel tank
- Replace engine oil and engine oil filter (3TNV74F, 3TNV80F, 3TNV80FT and 3TNM74F)
- Check and clean radiator fins
- Check and adjust cooling fan V-belt
- Check and adjust the governor lever and engine speed control
- Clean air cleaner element

■ Drain fuel tank

DANGER

Fire and Explosion Hazard!



- Diesel fuel is flammable and explosive under certain conditions.

- When you remove any fuel system component to perform maintenance (such as changing the fuel filter) place an approved container under the opening to catch the fuel.
- Never use a shop rag to catch the fuel. Vapors from the rag are flammable and explosive.
- Wipe up any spills immediately.
- Wear eye protection. The fuel system is under pressure and fuel could spray out when you remove any fuel system component.
- Failure to comply will result in death or serious injury.

NOTICE



- Always be environmentally responsible.

- Follow the guidelines of the EPA or other governmental agencies for the proper disposal of hazardous materials such as engine oil, diesel fuel and engine coolant. Consult the local authorities or reclamation facility.
- Never dispose of hazardous materials irresponsibly by dumping them into a sewer, on the ground, or into ground water or waterways.
- Failure to follow these procedures may seriously harm the environment.

Note that a typical fuel tank is illustrated.

1. Position an approved container under the diesel fuel tank (1, **Figure 7**) to collect the contaminants.
2. Remove the fuel cap (3, **Figure 7**).
3. Remove the drain plug (2, **Figure 7**) to drain the contaminants (water, dirt, etc.) from the bottom of the tank.
4. Drain the tank until clean diesel fuel with no water or dirt flows out. Reinstall and tighten the drain plug firmly.
5. Reinstall the fuel cap.
6. Check for leaks.

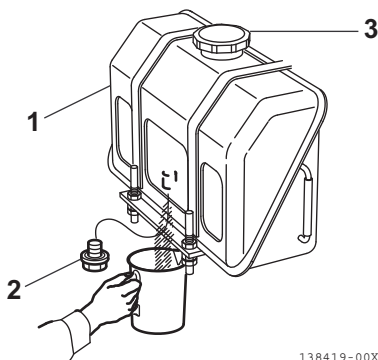

Figure 7

- Replace engine oil and engine oil filter (3TNV74F, 3TNV76F, 3TNV80F, 3TNV80FT and 3TNM74F)

WARNING

Burn Hazard!



- If you must drain the engine oil while it is still hot, stay clear of the hot engine oil to avoid being burned.
- Always wear eye protection.
- Failure to comply could result in death or serious injury.

NOTICE

- Only use the engine oil specified. Other engine oils may affect warranty coverage, cause internal engine components to seize and/or shorten engine life.
- Prevent dirt and debris from contaminating the engine oil. Carefully clean the oil cap/dipstick and the surrounding area before you remove the cap.
- Never mix different types of engine oil. This may adversely affect the lubricating properties of the engine oil.
- Never overfill. Overfilling may result in white exhaust smoke, engine overspeed or internal damage.

NOTICE



- Always be environmentally responsible.

- Follow the guidelines of the EPA or other governmental agencies for the proper disposal of hazardous materials such as engine oil, diesel fuel and engine coolant. Consult the local authorities or reclamation facility.
- Never dispose of hazardous materials irresponsibly by dumping them into a sewer, on the ground, or into ground water or waterways.
- Failure to follow these procedures may seriously harm the environment.

Change the engine oil every 250 hours of operation. Replace the engine oil filter at the same time.

Drain the engine oil as follows:

1. Make sure the engine is level.
2. Start the engine and bring it up to operating temperature.
3. Stop the engine.
4. Remove one of the oil filler caps (1, **Figure 8**) to vent the engine crankcase and allow the engine oil to drain more easily.
5. Position a container under the engine to collect waste oil.
6. Remove the oil drain plug (1, **Figure 9**) from the engine oil pan. Allow oil to drain.
7. After all oil has been drained from the engine, reinstall the oil drain plug (1, **Figure 9**) and tighten to 40 - 47 ft-lb (53.9 - 63.7 N·m, 5.5 - 6.5 kgf·m).
8. Dispose of used oil properly.

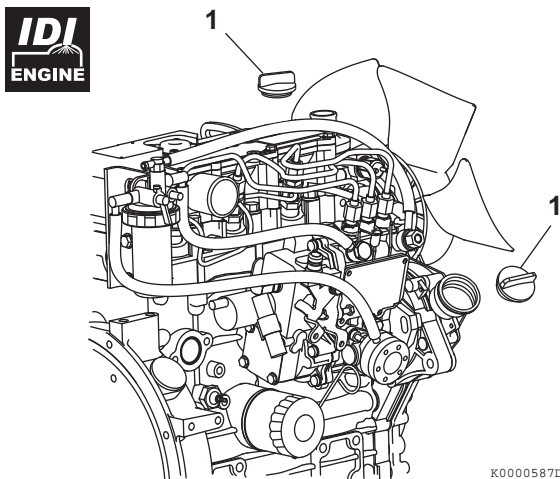

Figure 8

Note: The oil drain plug may be in another location if an optional oil pan is used.

■ Replace the engine oil filter

⚠ CAUTION

To refuel the engine oil, refuel slowly after removing the dipstick and both caps. If you refuel rapidly, the oil intrusion to the intake occurs through the PCV valve of the valve cover. It will result in an oil hammer at engine start, which may cause damage to the engine.

1. Turn the engine oil filter (2, **Figure 9**) counterclockwise (3, **Figure 9**) using an oil filter wrench.
2. Clean the engine oil filter mounting face.
3. Lightly coat the gasket on the new oil filter with engine oil. Install the new engine oil filter manually by turning it clockwise (4, **Figure 9**) until it contacts the mounting surface. Tighten to 14 - 17 ft-lb (19.6 - 23.5 N·m, 2.0 - 2.4 kgf·m) or one additional turn using the oil filter wrench.

 Engine oil filter part No.	
3TNM74F, 3TNV74F, 3TNV76F, 3TNV80F, 3TNV80FT	119305-35151 (68 × 65L)

4. Add new engine oil to the engine through either of the oil filler ports as specified in *Adding Engine Oil* on page 60.

NOTICE

- Never overfill the engine with engine oil.
- Always keep the oil level between the upper and lower lines on the oil cap/dipstick.

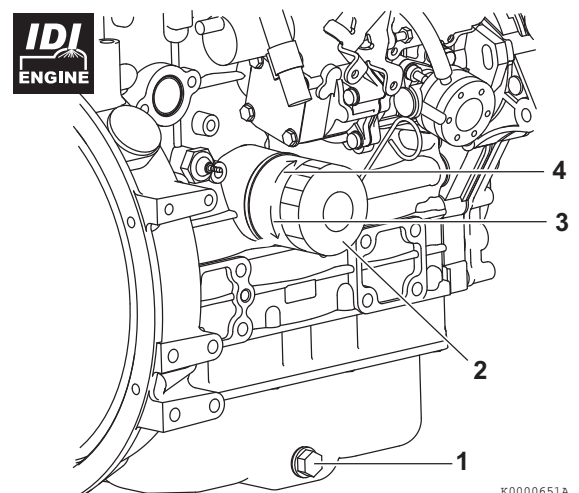

Figure 9

PERIODIC MAINTENANCE

5. Warm up the engine by running it for 5 minutes and check for any engine oil leaks.
6. After engine is warm, shut it off and let it sit for 10 minutes.
7. Recheck the engine oil level.
8. Add engine oil to engine oil filler port (5, **Figure 10**) as needed until the level is between the upper (2, **Figure 10**) and lower lines (3, **Figure 10**) shown on the dipstick (1, **Figure 10**).
9. Reinstall the oil filler cap (4, **Figure 10**). If any engine oil is spilled, wipe it away with a clean cloth.

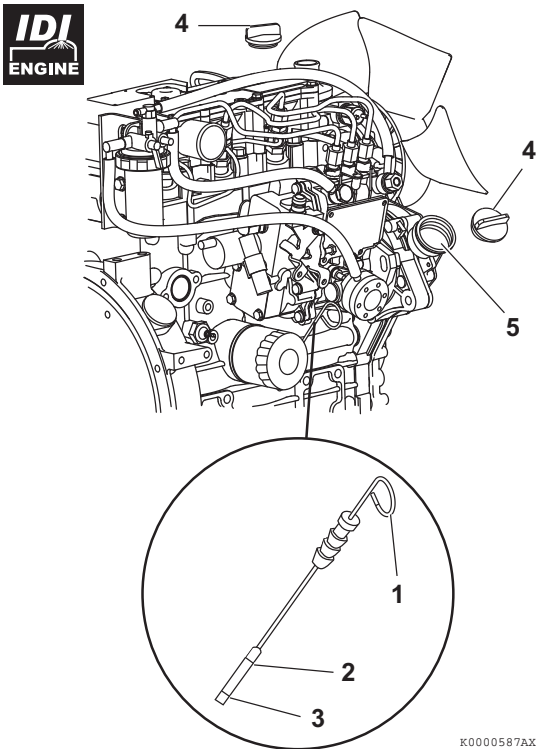
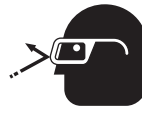

Figure 10

■ Check and clean radiator fins

⚠ CAUTION

Flying Object Hazard!



- Always wear eye protection when servicing the engine and when using compressed air or high-pressure water. Dust, flying debris, compressed air, pressurized water or steam may injure your eyes.

- Failure to comply may result in minor or moderate injury.

Dirt and dust adhering to the radiator fins reduce the cooling performance, causing overheating. Make it a rule to check the radiator fins daily and clean as needed.

Note that a typical radiator is shown in **Figure 11** for illustrative purposes only.

- Blow off dirt and dust from fins and radiator with 28 psi (0.19 MPa, 2 kgf/cm²) or less of compressed air (1, **Figure 11**). Be careful not to damage the fins with the compressed air.
- If there is a large amount of contamination on the fins, apply detergent, thoroughly clean and rinse with tap water.

NOTICE

Never use high-pressure water or compressed air at greater than 28 psi (193 kPa; 19686 mmAq) or a wire brush to clean the radiator fins. Radiator fins damage easily.

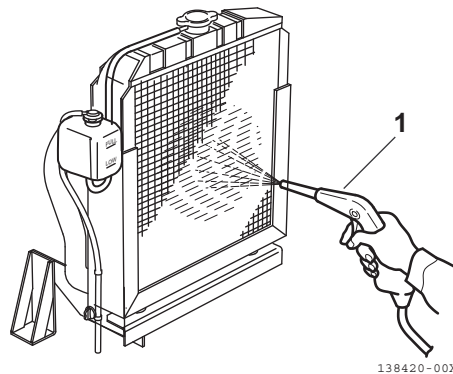

Figure 11

■ Check and adjust cooling fan V-belt

Check and adjust the cooling fan V-belt every 250 hours of operation after the initial 50 hour V-belt maintenance. See *Check and adjust cooling fan V-belt on page 80*.

■ Check and adjust the governor lever and engine speed control (except electronic controlled engines)

The governor lever and engine speed control (throttle lever, accelerator pedal etc.), are connected together by a cable or linkage. If the cable becomes stretched, or the linkage wears or loosens, the governor lever may not respond to a change in the position of the engine speed control.

NOTICE

Never attempt to adjust the low or high idle speed limit screw. This may impair the safety and performance of the machine and shorten its life. If the idle speed limit screws require adjustment, see your authorized YANMAR industrial engine dealer or distributor.

1. Check that the governor lever (1, **Figure 12**) makes firm contact with the high idle stop (2, **Figure 12**) and the low idle speed limit screw (3, **Figure 12**) when the engine speed control is in the full speed or low idle speed positions.
2. If the governor lever does not make proper contact with the high idle stop or the low idle speed limit screw, adjust the throttle cable or linkage as necessary.

Note: Do not force the throttle cable or linkage to move. This may damage the governor lever, the throttle cable or linkage and cause irregular operation of the engine speed control.

NOTICE

The engine speed control (throttle lever, accelerator pedal etc.), should be equipped with stops to prevent the application of excessive pressure by the governor lever to either the high idle stop or low idle speed limit screw.

See your authorized YANMAR industrial dealer or distributor for the adjustment procedures for your specific engine or machine.

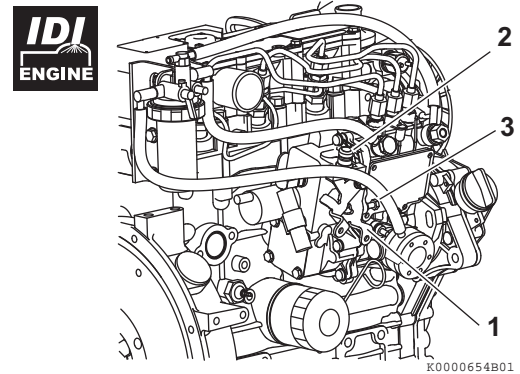

Figure 12

■ Clean air cleaner element

⚠ CAUTION

Flying Object Hazard!



- Always wear eye protection when servicing the engine and when using compressed air or high-pressure water. Dust, flying debris, compressed air, pressurized water or steam may injure your eyes.
- Failure to comply may result in minor or moderate injury.

Note that a typical air cleaner is shown in **Figure 13** and **Figure 14** for illustrative purposes only.

The engine performance is adversely affected when the air cleaner element is clogged with dust. Be sure to clean the air filter element periodically.

1. Unlatch and remove the air cleaner cover (1, **Figure 13**).
2. Remove the element (2, **Figure 13**) (outer element if equipped with two elements).
3. Blow air (3, **Figure 13**) through the element from the inside out using 42 - 71 psi (0.29 - 0.49 MPa, 3.0 - 5.0 kgf/cm²) compressed air to remove the particulates. Use the lowest possible air pressure to remove the dust without damaging the element.

PERIODIC MAINTENANCE

4. If the air cleaner is equipped with a double element, only remove and replace the inner element (1, **Figure 14**) if the engine lacks power or the dust indicator actuates (if equipped).

Note: The inner element should not be removed when cleaning or replacing the outer element. The inner element is used to prevent dust from entering the engine while servicing the outer element.

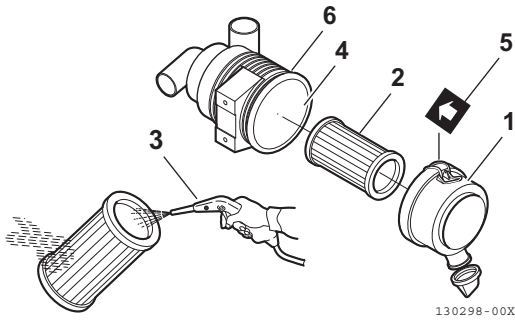

Figure 13

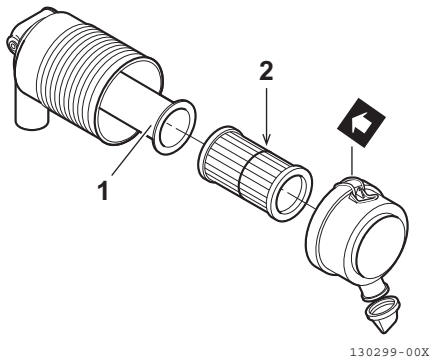

Figure 14

5. Replace the element with a new one if the element is damaged, excessively dirty or oily.
6. Clean inside of the air cleaner cover.
7. Reinstall the element into the air cleaner case (4, **Figure 13**).

*Note: If there is a red line (2, **Figure 14**) in the outer element, reinsert the element until the overlap position of red line and end face of the air cleaner case.*

8. Reinstall the air cleaner cover making sure you match the arrow (5, **Figure 13**) on the cover with the arrow on the case (6, **Figure 13**).
9. Latch the air cleaner cover to the case.

NOTICE

- When the engine is operated in dusty conditions, clean the air cleaner element more frequently.
- Never operate the engine with the air cleaner element(s) removed. This may allow foreign material to enter the engine and damage it.

Every 500 Hours of Operation

Perform the following maintenance every 500 hours of operation.

- Replace air cleaner element
- Replace fuel filter (element)
- Clean water separator
- Replace engine oil and engine oil filter (only 3TNV88F)

■ Replace air cleaner element

NOTICE

The maximum air intake restriction, in terms of differential pressure measurement, must not exceed 0.90 psi (6.23 kPa; 635 mmAq). Clean or replace the air cleaner element if the air intake restriction exceeds the above mentioned value.

Replace the air cleaner element (2, **Figure 13**) every 500 hours even if it is not damaged or dirty.

When replacing the element, clean the inside of the air cleaner case (4, **Figure 13**).

If the air cleaner is equipped with a double element, *only remove and replace the inner element (1, **Figure 14**) if the engine lacks power or the dust indicator actuates (if equipped)*. This is in addition to replacing the outer element.

■ Replace fuel filter (element)

⚠ DANGER

Fire and Explosion Hazard!



- Diesel fuel is flammable and explosive under certain conditions.

- When you remove any fuel system component to perform maintenance (such as changing the fuel filter) place an approved container under the opening to catch the fuel.
- Never use a shop rag to catch the fuel. Vapors from the rag are flammable and explosive.
- Wipe up any spills immediately.
- Wear eye protection. The fuel system is under pressure and fuel could spray out when you remove any fuel system component.
- Failure to comply will result in death or serious injury.

NOTICE

For maximum engine life, YANMAR recommends that when shutting the engine down, you allow the engine to idle, without load, for five minutes. This will allow the engine components that operate at high temperatures, such as the turbocharger (if equipped) and exhaust system, to cool slightly before the engine itself is shut down.

NOTICE



- Always be environmentally responsible.

- Follow the guidelines of the EPA or other governmental agencies for the proper disposal of hazardous materials such as engine oil, diesel fuel and engine coolant. Consult the local authorities or reclamation facility.
- Never dispose of hazardous materials irresponsibly by dumping them into a sewer, on the ground, or into ground water or waterways.
- Failure to follow these procedures may seriously harm the environment.

PERIODIC MAINTENANCE



Replace the fuel filter element at specified intervals to prevent contaminants from adversely affecting the diesel fuel flow.

1. Stop the engine and allow it to cool.
2. Close the fuel valve of the water separator.
3. Turn the retaining ring (1, **Figure 15**) to the left (5, **Figure 15**).
4. Carefully remove the cup (3, **Figure 15**). Pour the fuel into an approved container and dispose of waste properly. Hold the bottom of the cup with a shop towel to prevent the fuel from dripping. Wipe up any spills immediately.
5. Remove the fuel filter element (4, **Figure 15**) by pulling it down.
6. Replace the fuel filter element with a new one.

Applicable fuel filter element part No.		
	Standard	Dust proof*
3TNM74F, 3TNV74F, 3TNV76F, 3TNV80F, 3TNV80FT	119810-55650	119802-55801

* This is a fuel filter for DI, and should be installed with a different filter bracket. Consult the operation manual for the driven machine for applicability of the dust proof filter.

7. Wash the inside of the cup.
8. Check the condition of the O-ring (6, **Figure 15**). Replace if necessary.
9. Install the cup to the mounting flange and turn the retaining ring (1, **Figure 15**) to the right (2, **Figure 15**). Hand-tighten only.
10. Open the fuel valve of the water separator.
11. Prime the fuel system. See *Priming the Fuel System* on page 58.
12. Check for fuel leaks.

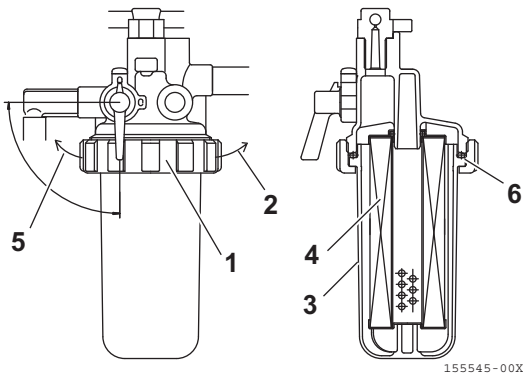

Figure 15



Replace the fuel filter at specified intervals to prevent contaminants from adversely affecting the diesel fuel flow.

1. Stop the engine and allow it to cool.
2. Close the fuel valve of the water separator.
3. Remove the fuel filter using a filter wrench to turn it to the left (1, **Figure 16**). When removing the fuel filter, carefully hold it to prevent the fuel from spilling. Wipe up all spilled fuel.

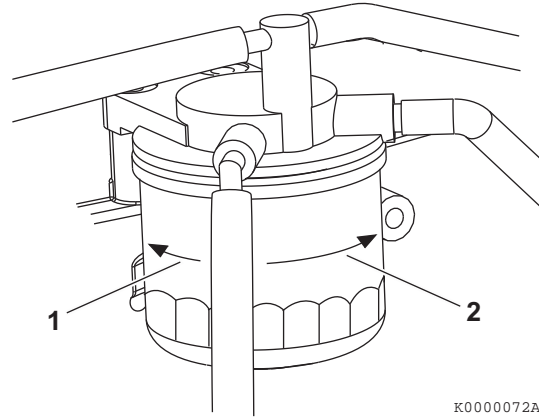

Figure 16

4. Clean the filter mounting surface and apply a small amount of diesel fuel to the gasket of the new fuel filter.
5. Install the new fuel filter. Hand-tighten it to the right (2, **Figure 16**) until it comes in contact with the mounting surface. Use a filter wrench and tighten to 14 - 17 ft-lb (19.6 - 23.5 N·m, 2.0 - 2.4 kgf·m) or one additional turn using the filter wrench.

Applicable fuel filter part No.		
	Standard	Dust proof*
3TNV88F	119802-55801	129907-55801

* Consult the operation manual for the driven machine for applicability of the dust proof filter.

6. Open the fuel valve of the water separator.
7. Prime the fuel system. See *Priming the Fuel System* on page 58.
8. Check for fuel leaks.

■ Clean water separator

⚠ DANGER

Fire and Explosion Hazard!



- Diesel fuel is flammable and explosive under certain conditions.

- Never use diesel fuel as a cleaning agent.
- When you remove any fuel system component to perform maintenance (such as changing the fuel filter) place an approved container under the opening to catch the fuel.
- Never use a shop rag to catch the fuel. Vapors from the rag are flammable and explosive.
- Wipe up any spills immediately.
- Wear eye protection. The fuel system is under pressure and fuel could spray out when you remove any fuel system component.
- Failure to comply will result in death or serious injury.

NOTICE



- Always be environmentally responsible.

- Follow the guidelines of the EPA or other governmental agencies for the proper disposal of hazardous materials such as engine oil, diesel fuel and engine coolant. Consult the local authorities or reclamation facility.
- Never dispose of hazardous materials irresponsibly by dumping them into a sewer, on the ground, or into ground water or waterways.
- Failure to follow these procedures may seriously harm the environment.



Periodically clean the water separator element and inside cup.

1. Position an approved container under the cup (1, **Figure 17**) of the water separator to collect the contaminants.
2. Close (2, **Figure 17**) the fuel valve (3, **Figure 17**).
3. Turn the retaining ring (4, **Figure 17**) to the left (9, **Figure 17**).
4. Carefully remove the cup (1, **Figure 17**). Remove the retaining spring (6, **Figure 17**) and float (7, **Figure 17**) from the cup. Pour the fuel into an approved container and dispose of waste properly. Hold the bottom of the cup with a shop towel to prevent the fuel from dripping. Wipe up any spills immediately.
5. Remove the element by pulling it down (10, **Figure 17**).
6. Wash the inside of the element and cup with new fuel. If the element is damaged or broken, replace with a new one.

Applicable mesh filter part No.	
3TNM74F, 3TNV74F, 3TNV76F, 3TNV80F, 3TNV80FT	171081-55910

7. Attach the element to the main body.
8. Inspect condition of the O-ring (11, **Figure 17**). Replace if necessary.
9. Put the float (7, **Figure 17**) and retaining spring (6, **Figure 17**) inside the cup.
10. Install the cup to the mounting flange (8, **Figure 17**) and turn the retaining ring (4, **Figure 17**) to the right (5, **Figure 17**). Hand-tighten only.
11. Open the fuel valve (3, **Figure 17**).
12. Prime the fuel system. *See Priming the Fuel System on page 58.*
13. Check for fuel leaks.

PERIODIC MAINTENANCE

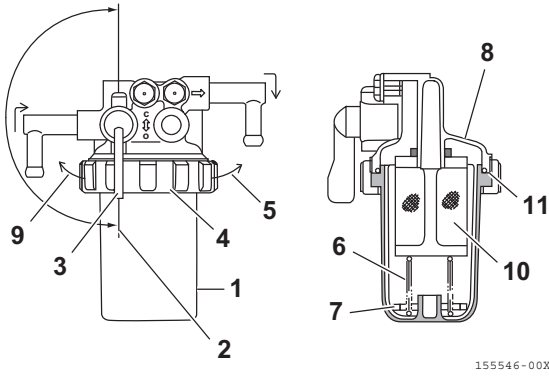

Figure 17



Periodically clean the water separator element and inside the cup.

1. Position an approved container under the cup (1, **Figure 18**) of the water separator to collect the contaminants.
2. Close (2, **Figure 18**) the fuel valve (3, **Figure 18**).
3. Loosen the drain valve (4, **Figure 18**) and drain the contaminants. *See Drain water separator on page 82.*
4. Turn the cup (1, **Figure 18**) to the left (10, **Figure 18**) and remove the cup (1, **Figure 18**). If equipped, disconnect the sensor wire from the cup before removing the cup.
5. Carefully hold the cup to prevent fuel from spilling. If you spill any fuel, clean up the spill completely.

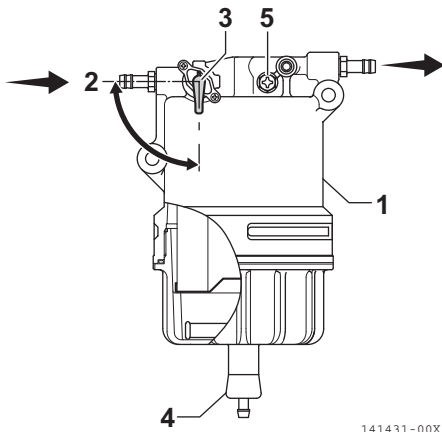

Figure 18

6. Remove the float ring (8, **Figure 18**) from the cup. Pour the contaminants into the container and dispose of it properly.
7. Clean the element (9, **Figure 18**) and inside cup. Replace the element if it is damaged.

Applicable element part No.	
3TNV88F	129242-55730

8. Install the element into the top of body.
9. Position the float ring in the cup.
10. Check the condition of the O-ring. Replace if necessary.
11. Install the cup to the body by tightening the cup to the right (6, **Figure 18**) to 18 - 22 N·m (1.8 - 2.2 kgf·m).
12. Close the drain valve. Reconnect the sensor wire if equipped.
13. Open the fuel valve (3, **Figure 18**).
14. Prime the fuel system. *See Priming the Fuel System on page 58.*
15. Check for leaks.

■ Replace engine oil and engine oil filter (3TNV88F)

⚠ WARNING

Burn Hazard!



- If you must drain the engine oil while it is still hot, stay clear of the hot engine oil to avoid being burned.

- Always wear eye protection.
- Failure to comply could result in death or serious injury.

NOTICE

- Only use the engine oil specified. Other engine oils may affect warranty coverage, cause internal engine components to seize and/or shorten engine life.
- Prevent dirt and debris from contaminating the engine oil. Carefully clean the oil cap/dipstick and the surrounding area before you remove the cap.
- Never mix different types of engine oil. This may adversely affect the lubricating properties of the engine oil.
- Never overfill. Overfilling may result in white exhaust smoke, engine overspeed or internal damage.

NOTICE



- Always be environmentally responsible.

- Follow the guidelines of the EPA or other governmental agencies for the proper disposal of hazardous materials such as engine oil, diesel fuel and engine coolant. Consult the local authorities or reclamation facility.
- Never dispose of hazardous materials irresponsibly by dumping them into a sewer, on the ground, or into ground water or waterways.
- Failure to follow these procedures may seriously harm the environment.

Change the engine oil every 500 hours or 1 year of operation. Replace the engine oil filter at the same time.

If the engine is equipped with a shallow type oil sump, the maintenance interval for the engine oil and filter should be every 250 hours regardless of the implement.

Drain the engine oil as follows:

1. Make sure the engine is level.
2. Start the engine and bring it up to operating temperature.
3. Stop the engine.
4. Remove one of the oil filler caps (1, **Figure 19**) to vent the engine crankcase and allow the engine oil to drain more easily.
5. Position a container under the engine to collect waste oil.
6. Remove the oil drain plug (1, **Figure 20**) from the engine oil pan. Allow oil to drain.
7. After all oil has been drained from the engine, reinstall the oil drain plug (1, **Figure 20**) and tighten to 40 - 47 ft-lb (53.9 - 63.7 N·m, 5.5 - 6.5 kgf·m).
8. Dispose of used oil properly.

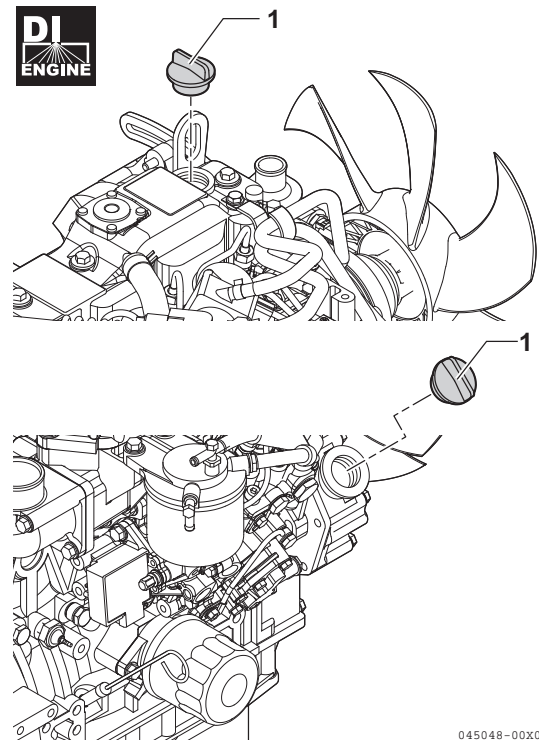

045048-00x01

Figure 19

Note: The oil drain plug may be in another location if an optional oil pan is used.

PERIODIC MAINTENANCE

■ Replace the engine oil filter

⚠ CAUTION

To refuel the engine oil, refuel slowly after removing the dipstick and both caps. If you refuel rapidly, the oil intrusion to the intake occurs through the PCV valve of the valve cover. It will result in an oil hammer at engine start, which may cause damage to the engine.

1. Turn the engine oil filter (2, **Figure 20**) counterclockwise (3, **Figure 20**) using an oil filter wrench.
2. Clean the engine oil filter mounting face.
3. Lightly coat the gasket on the new oil filter with engine oil. Install the new engine oil filter manually by turning it clockwise (4, **Figure 20**) until it contacts the mounting surface. Tighten to 14 - 17 ft-lb (19.6 - 23.5 N·m, 2.0 - 2.4 kgf·m) or one additional turn using the oil filter wrench.

DI ENGINE	Engine oil filter part No.	
	Standard	Dust proof*
3TNV88F	129150-35153 (80 × 80L)	119005-35151 (80 × 100L)

* Consult the operation manual for the driven machine for applicability of the dust proof filter.

4. Add new engine oil to the engine through either of the oil filler ports as specified in *Adding Engine Oil* on page 60.

NOTICE

- Never overfill the engine with engine oil.
- Always keep the oil level between the upper and lower lines on the oil cap/dipstick.

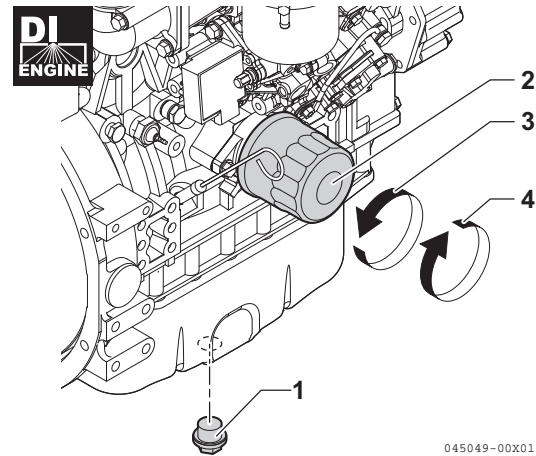

Figure 20

5. Warm up the engine by running it for 5 minutes and check for any engine oil leaks.
6. After engine is warm, shut it off and let it sit for 10 minutes.
7. Recheck the engine oil level.
8. Add engine oil to engine oil filler port (5, **Figure 21**) as needed until the level is between the upper (2, **Figure 21**) and lower lines (3, **Figure 21**) shown on the dipstick (1, **Figure 21**).
9. Reinstall the oil filler cap (4, **Figure 21**). If any engine oil is spilled, wipe it away with a clean cloth.

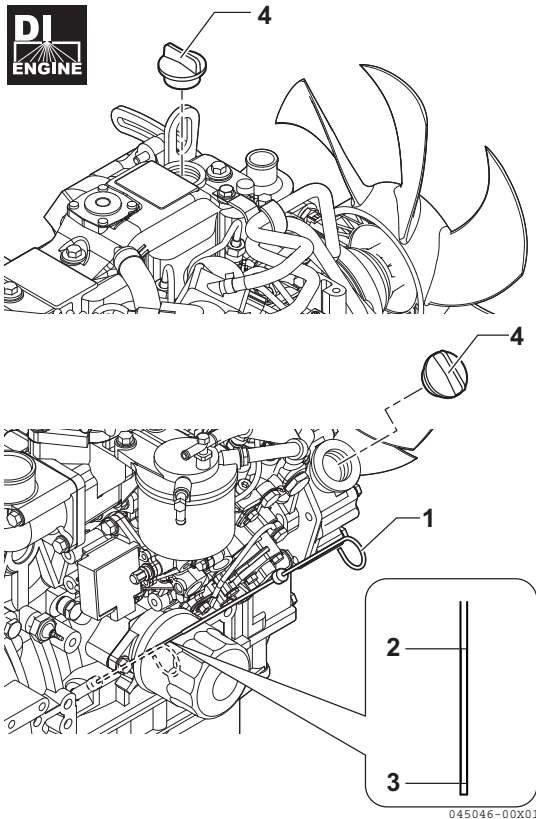

Figure 21

Every 1000 Hours of Operation

Perform the following maintenance every 1000 hours of operation.

- **Check and adjust intake/exhaust valve clearance**
- **Check and adjust intake/exhaust valve clearance**

Improper intake/exhaust valve clearance will cause the engine to run noisily, resulting in poor engine performance and engine damage. Proper adjustment is necessary to maintain the correct timing for opening and closing the valves. See your authorized YANMAR industrial engine dealer or distributor to inspect and adjust the intake/exhaust valve clearance.

PERIODIC MAINTENANCE

Every 1500 Hours of Operation

Perform the following maintenance every 1500 hours of operation.

- Inspect and clean fuel injection nozzle
- Inspect crankcase breather system
- Inspect, clean and test fuel injection nozzle

WARNING

High-Pressure Hazard!



- While the engine is running or right after the engine has stopped, there is still high-pressure fuel left in the fuel piping system. When you need to disassemble the fuel system, wait for 10 to 15 minutes after stopping the engine.
- If fuel is spraying out or leaking from broken fuel system such as high-pressure fuel injection lines, it may be in high-pressure. Avoid skin contact. High-pressure fuel can penetrate your skin and result in serious injury. If you are exposed to high-pressure fuel spray, obtain prompt medical treatment.
- Disassembling or repairing the fuel system shall be done by professionals such as the authorized YANMAR distributor or dealer.
- Failure to comply could result in death or serious injury.

Proper operation of the fuel injection nozzle is required to obtain the optimum injection pattern for full engine performance. The EPA/ARB requires that you have the fuel injection nozzle inspected, cleaned and tested every 1500 hours. See your authorized YANMAR industrial engine dealer or distributor for this service.

This procedure is considered normal maintenance and is performed at the owner's expense. This procedure is not covered by the YANMAR Limited Warranty.

■ Inspect crankcase breather system

Proper operation of the crankcase breather system is required to maintain the emission requirements of the engine. The EPA/ARB requires that you have the crankcase breather system inspected every 1500 hours. See your authorized YANMAR industrial engine dealer or distributor for this service.

Every 2000 Hours of Operation

Perform the following maintenance every 2000 hours of operation.

- Check and replace fuel hoses and engine coolant hoses
- Change coolant

⚠ DANGER

Scald Hazard!



- Never remove the radiator cap if the engine is hot. Steam and hot engine coolant will spurt out and seriously burn you. Allow the engine to cool down before you attempt to remove the radiator cap.

- Tighten the radiator cap securely after you check the radiator. Steam can spurt out during engine operation if the cap is loose.
- Always check the level of the engine coolant by observing the reserve tank.
- Failure to comply will result in death or serious injury.

⚠ WARNING

Burn Hazard!



- If you must drain the engine oil while it is still hot, stay clear of the hot engine oil to avoid being burned.

- Always wear eye protection.
- Failure to comply could result in death or serious injury.

⚠ CAUTION

Engine Coolant Hazard!

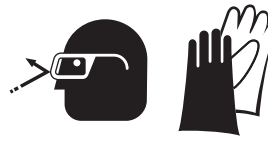

- Wear eye protection and rubber gloves when you handle long life or extended life engine coolant. If contact with the eyes or skin should occur, flush eyes and wash immediately with clean water.

- Failure to comply may result in minor or moderate injury.

NOTICE



- Always be environmentally responsible.

- Follow the guidelines of the EPA or other governmental agencies for the proper disposal of hazardous materials such as engine oil, diesel fuel and engine coolant. Consult the local authorities or reclamation facility.
- Never dispose of hazardous materials irresponsibly by dumping them into a sewer, on the ground, or into ground water or waterways.
- Failure to follow these procedures may seriously harm the environment.

■ Check and replace fuel hoses and engine coolant hoses

Regularly check the fuel system and engine coolant system hoses. If they are cracked or degraded, replace them. Replace the hoses at least every two years. See your authorized YANMAR industrial engine dealer or distributor to replace fuel hoses and engine coolant system hoses.

PERIODIC MAINTENANCE

■ Change coolant

Engine coolant contaminated with rust or water scale reduces the cooling effect. Even when extended life engine coolant is properly mixed, the engine coolant gets contaminated as its ingredients deteriorate. Drain, flush and refill the cooling system with new coolant every 2000 hours or once 2 years, whichever comes first.

1. Allow engine and coolant to cool.
2. Remove the radiator cap (1, **Figure 22**).
3. Remove the drain plug or open the drain valve (2, **Figure 22**) at the bottom of the radiator and drain the engine coolant.

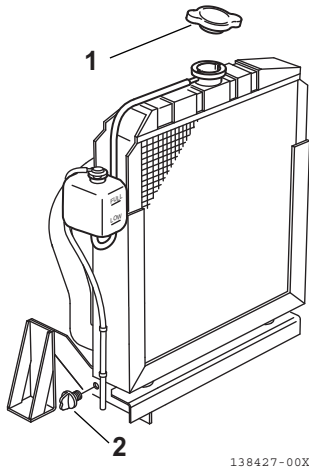
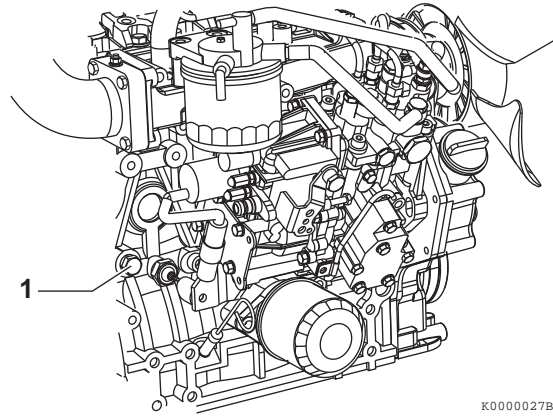

Figure 22

4. Drain the coolant from the engine block.
 - On models not equipped with an oil cooler, remove the coolant drain plug (1, **Figure 23**) from the engine block.



K0000027B

Figure 23

5. After draining the engine coolant, flush the radiator and engine block to remove any rust, scale and contaminants. Then reinstall and tighten the drain plug or close the drain valve in the radiator. Reinstall and tighten the engine block drain plug.
6. Fill radiator and engine with engine coolant. See *Filling Radiator with Engine Coolant* on page 63.

Every 3000 Hours of Operation

Perform the following maintenance every 3000 hours of operation.

- **Inspect, clean and test fuel injection nozzle, if necessary**
- **Inspect ECU and related sensors and actuators**
3TNV80FT, 3TNV88F-E, 3TNV80F-Z
- **Inspect turbocharger (blower wash as necessary)**
3TNV80FT
- **Inspect, clean and test EGR valve**
3TNV88F-E

Inspect ECU and related sensors and actuators

3TNV80FT, 3TNV88F-E, 3TNV80F-Z

Inspect the appearance and wirings of the ECU and related sensors and actuators, and check the occurrence status and error history of the engine failure lamp and warning lamps on the control panel. If necessary, a more detailed checkup can be done using a diagnosis tool (SA-D). For detailed checkup, always contact your authorized YANMAR dealer who can handle SA-D.

Inspect turbocharger (blower wash as necessary)

3TNV80FT

Turbocharger service is required by the EPA/ARB every 3000 hours. Your authorized YANMAR industrial engine dealer or distributor will inspect and blower wash the unit if necessary. If you notice that the engine seems sluggish or the exhaust color is abnormal never wait until the next periodic interval. Have your YANMAR dealer or distributor service the turbocharger as soon as possible.

Inspect, clean and test EGR valve

3TNV88F-E

The EGR valve is a key component for cleaning exhaust gas.

To prevent the valve from deteriorating in exhaust gas recirculation performance due to carbon accumulation, inspect, clean and test the valve at least every 3000 hours.

Consult your local YANMAR dealer for this service.

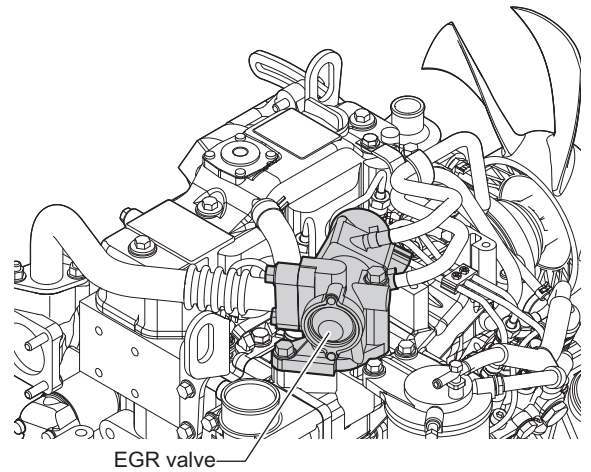

045050-00EN00

Figure 24

This Page Intentionally Left Blank

TROUBLESHOOTING

If a problem occurs, stop the engine immediately. Refer to the Symptom column in the Troubleshooting Chart to identify the problem.

NOTICE

If any indicator fails to illuminate when the key switch is in the ON position, see your authorized YANMAR industrial engine dealer or distributor for service before operating the engine.

If any indicator illuminates during engine operation, stop the engine immediately. Determine the cause and repair the problem before you continue to operate the engine.

TROUBLESHOOTING

TROUBLESHOOTING CHART

Symptom	Probable cause	Action	Refer to
Indicator turns ON - engine running			
Engine oil pressure indicator	Low level of engine oil	Check and adjust oil level as necessary	<i>Checking Engine Oil on page 60</i>
	Too high an oil level		
Engine oil pressure indicator	Clogged engine oil filter	Replace engine oil filter	<i>Replace engine oil and engine oil filter (3TNV74F, 3TNV76F, 3TNV80F, 3TNV80FT and 3TNM74F) on page 86</i>
	Engine coolant indicator		
Engine coolant indicator	Low engine coolant level	Add engine coolant	<i>Filling Radiator with Engine Coolant on page 63</i>
	Dirty radiator fins	Clean the radiator fins	<i>Check and clean radiator fins on page 88</i>
	Engine coolant leaking	See authorized YANMAR industrial engine dealer or distributor	–
	V-belt loose or damaged	Adjust V-belt or replace	<i>Check and adjust cooling fan V-belt on page 80</i>
	Contaminated engine coolant	See authorized YANMAR industrial engine dealer or distributor	–
	Faulty engine coolant pump		–
Battery Indicator	V-belt loose or damaged	Adjust V-belt or replace	<i>Check and adjust cooling fan V-belt on page 80</i>
	Battery failure	Check battery condition	<i>Check battery and recharge on page 84</i>
	Faulty alternator	See authorized YANMAR industrial engine dealer or distributor	–
Indicator does not turn ON - key switch is turned to ON (OFF → ON) - engine not running			
	Faulty electrical wiring or faulty indicator	See authorized YANMAR industrial engine dealer or distributor	–
Indicator stays ON - key switch is turned from start to ON (START → ON) - engine not running			
Battery indicator stays ON	Faulty alternator	See authorized YANMAR industrial engine dealer or distributor	–
Engine oil pressure indicator stays ON	Faulty engine oil pressure switch		–
	No or low level of engine oil	Check and adjust oil level as necessary	<i>Checking Engine Oil on page 60</i>
	Clogged engine oil filter	Replace engine oil filter	<i>Replace engine oil and engine oil filter (3TNV74F, 3TNV76F, 3TNV80F, 3TNV80FT and 3TNM74F) on page 86</i>

Symptom	Probable cause	Action	Refer to
Engine does not Start			
Starter motor operates but engine does not start	No diesel fuel	Refuel and prime fuel system	<i>Filling the Fuel Tank on page 57</i>
	Air in fuel system	Prime fuel system	<i>Priming the Fuel System on page 58</i>
	Improper diesel fuel	Replace with recommended diesel fuel	<i>Diesel Fuel Specifications on page 54</i>
	Clogged fuel filter	Replace fuel filter	<i>Replace fuel filter (element) on page 91</i>
	Poor fuel injection	See authorized YANMAR industrial engine dealer or distributor	–
	Compressed air leakage from intake/exhaust valves		–
	Faulty engine stop solenoid		–
Starter motor does not operate or rotates too slowly (engine can be turned manually)	Battery needs charging	Check electrolyte, recharge	<i>Check battery and recharge on page 84</i>
	Faulty cable connection at battery terminals	Clean terminals, retighten	–
	Faulty starter switch	See authorized YANMAR industrial engine dealer or distributor	–
	Faulty starter motor		–
Engine cannot be manually turned	Inner parts seized or damaged		–
White or black exhaust smoke			
Black exhaust smoke	Engine overloaded	Reduce load	–
	Clogged air cleaner element	Clean element or replace	<i>Clean air cleaner element on page 89</i>
	Improper diesel fuel	Replace with recommended diesel fuel	<i>Diesel Fuel Specifications on page 54</i>
	Faulty spraying of fuel injection	See authorized YANMAR industrial engine dealer or distributor	–
	Excessive intake/exhaust valve clearance		–
	Faulty EGR valve		–
White exhaust smoke	Improper diesel fuel	Replace with recommended diesel fuel	<i>Diesel Fuel Specifications on page 54</i>
	Faulty spray pattern of fuel injection	See authorized YANMAR industrial engine dealer or distributor	–
	Fuel injection timing delay		–
	Engine burning oil		–

TROUBLESHOOTING OF ELECTRONIC CONTROL SYSTEM



3TNV88F-E



3TNV80FT, 3TNV80F-Z

⚠ WARNING

- Never use the ECU for purposes that are not intended by YANMAR; such as using unauthorized ECU, writing unauthorized data to ECU, leaving it broken, or removing sensors and actuators. Doing so could result in the violation of emission control regulations and will void the product warranty.
- Be sure to use the ECU in conjunction with the engines whose models or serial numbers are specified by YANMAR. Other ECU/engine combinations than specified will void the engine warranty.
- Replacing the fuel injection pump involves rewriting the fuel injection data in the ECU. Be sure to contact your local YANMAR dealer before replacing the fuel injection pump. Failure to rewrite the fuel injection data before replacing the fuel injection pump will void the engine warranty.
- Replacing the ECU involves migrating the fuel injection data to the existing ECU to the new unit. Be sure to contact your local YANMAR dealer before replacing the ECU. Failure to migrate the fuel injection data before replacing the ECU will void the engine warranty.
- Improper use or misuse of the ECU may result in death or serious injury due to an abrupt and unexpected increase in engine speed.

Fault Detection Capability

The ECU has a fault detection capability. See *List of Possible Faults of Electronic Controlled Engines* on page 110.

A engine failure lamp (Optional) is located on the operator's console as shown in **Figure 1**.

This indicator comes on at power up of the ECU and goes out after 2 sec.

Once a fault is detected, then the indicator flashes in certain patterns, providing fault information to the operator.

NOTICE

Shut down the engine if the engine failure lamp comes on. Continuing running the engine with the engine failure lamp being on may result in a serious malfunction of or damage to the engine, and will void the engine warranty.

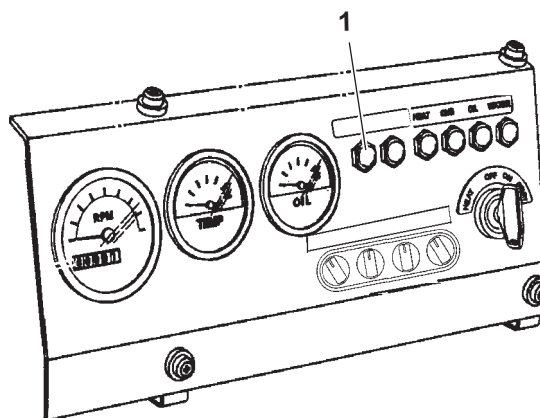

1 – Engine failure lamp

Figure 1

Note: **Figure 1** Typical operator's console

Figure 2 exemplifies flashing patterns that represent an accelerator fault (5 flashes) or EGR valve fault (1 to 3 flashes) occurring at power up. If multiple faults occur simultaneously, the engine failure lamp indicates all the faults in order of smaller to larger number of flashes.

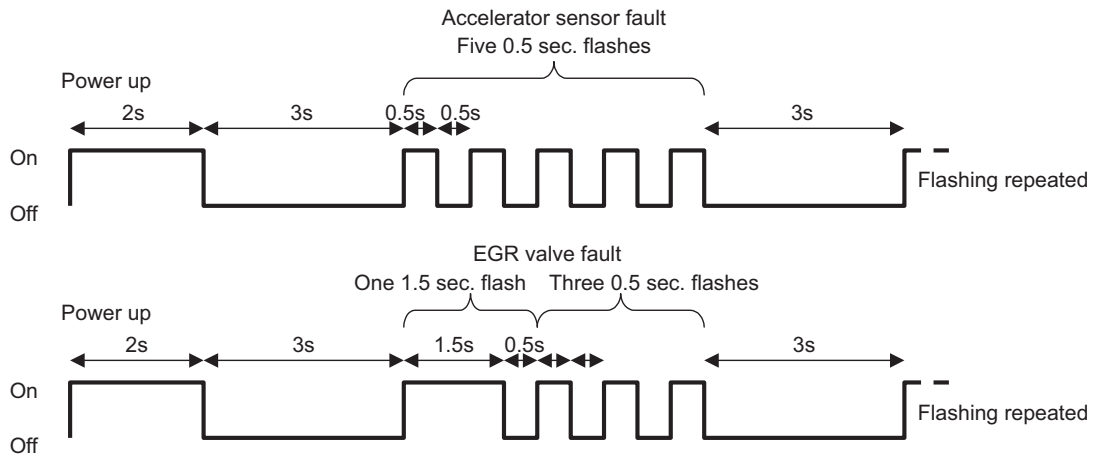

Figure 2

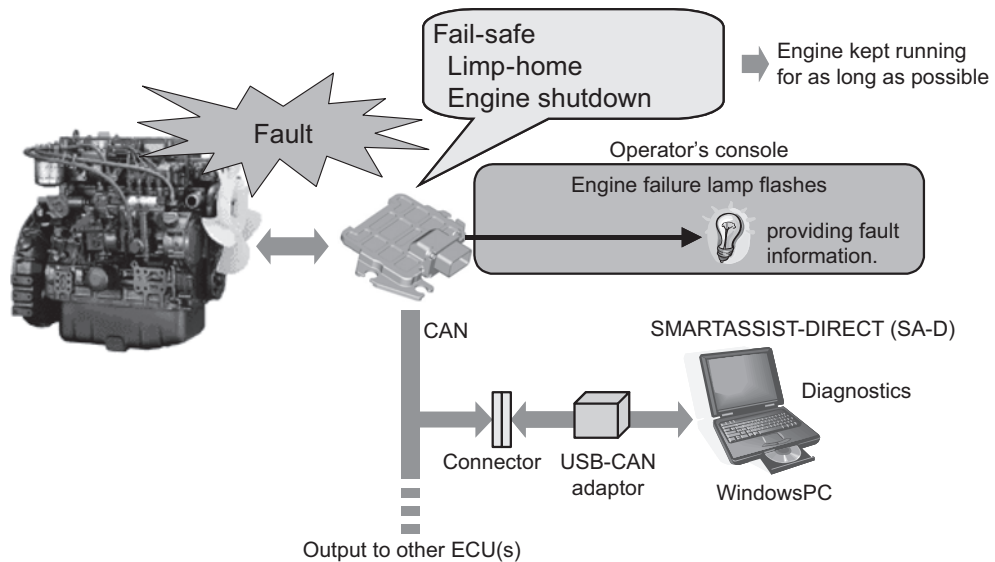

Figure 3

NOTICE

If the engine failure lamp comes on, check and note the flashing pattern, shut down the engine without delay and contact your local YANMAR dealer.

SMARTASSIST-DIRECT (SA-D), YANMAR genuine diagnosis tool, allows reviewing detailed fault information, historical fault/alarm logs and freeze frame data, monitoring the engine status and carrying out the fault diagnosis. See **Figure 3**.

Events in the fault/alarm logs can be time stamped.

SMARTASSIST-DIRECT

A connector is provided at an end of the harness of the driven machine so that the YANMAR genuine SMARTASSIST-DIRECT can be loaded with data from the ECU. See **Figure 4** and **Figure 5**.

When the fuel injection pump is replaced, data in the ECU must also be replaced for accommodating the new pump. When the ECU is replaced, the fuel injection data in the existing unit must be migrated to the new unit. The diagnosis tool can be used for the data replacement or migration. Contact your local YANMAR dealer for replacement of the fuel injection pump or ECU.

For operation of the SMARTASSIST-DIRECT, see the SA-D operation manual for the tool.

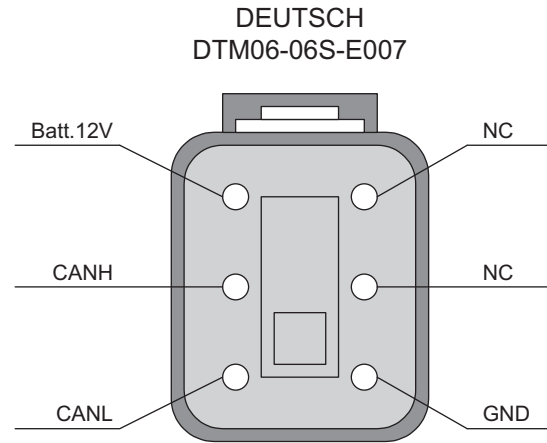

Mating connector (Tool side)
DEUTSCH
DTM04-06P-E003

Figure 5

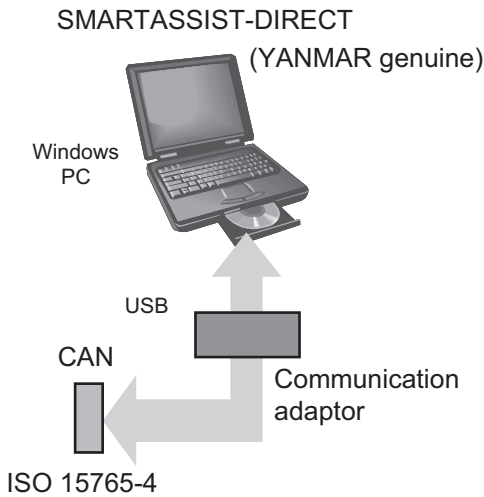

Figure 4

TROUBLESHOOTING INFORMATION

If your engine does not operate properly, refer to the troubleshooting chart or consult your authorized YANMAR industrial engine dealer or distributor.

Supply the authorized YANMAR industrial engine dealer or distributor with the following information:

- Model name and serial number of your engine
- The driven machine type (tractor, generator, skid steer loader), manufacturer's name, model and serial number
- How long the engine has been in service (the number of engine hours or the number of calendar months)
- Operating conditions when problem occurs:
 - Engine speed
 - Color of exhaust smoke
 - Type of diesel fuel
 - Type of engine oil
 - Flashing patterns of engine failure lamp (When an electronic controlled engine and the engine failure lamp are used)
 - Any abnormal noises or vibration
 - Operating environment such as high altitude or extreme ambient temperatures, etc.
- Engine maintenance history and previous problems
- Other factors that contribute to the problem

LIST OF POSSIBLE FAULTS OF ELECTRONIC CONTROLLED ENGINES



3TNV88F-E



3TNV80FT, 3TNV80F-Z

No.	Fault (alarm) location	Fault/alarm condition	Engine status	Reset condition	Availability of detection features	No. of flashes/flashing pattern of engine failure lamp
1	Coolant temperature sensor	Sensor voltage is over 4.8 V or under 0.2 V	Continues to run at a coolant temperature of 30 °C	Voltage returns to normal	Standard	4
2	Accelerator sensor	Sensor voltage is over 4.8 V or under 0.2 V	Continues to run at 1500 min ⁻¹ (rpm)	Voltage returns to normal	Default	5
3	Speed sensor	Engine start switch (E8) is on, but engine speed is zero	Is shut down. (When optional auxiliary speed sensor is equipped: Auxiliary speed sensor works in place of faulty speed sensor and engine continues to run at up to 1800 min ⁻¹ (rpm). If auxiliary sensor also fails, engine is shut down.	Key switch is turned to OFF	Standard	6
		Engine speed momentarily decreased to lower than specified lower limit				
4	Rack position sensor	Rack position relative to rack actuator is without specified limits.	Continues to run without rack position sensing at up to 150% of low idling speed or 80% of high idling speed, whichever is lower	Key switch is turned to OFF	Standard	7
5	Rack actuator	Rack actuator output is without specified limits	Is shut down	Key switch is turned to OFF	Standard	8
		Engine accelerates even though rack actuator output is minimized				
		Engine stalls while rack position sensor fails				
6	EGR valve (3TNV80F-E)	LOW status was detected even though port was off	Continues to run at up to 92% of rated power output and up to 1800 min ⁻¹ (rpm)	Key switch is turned to OFF	Default	1-3
		HIGH status was detected even though port was on				
7	CSD solenoid valve (3TNV80F-E)	LOW status was detected even though port was on	Continues to run while CSD feature is canceled	Key switch is turned to OFF	Standard	1-4
		HIGH status was detected even though port was off				
8	Starting aid relay	LOW status was detected even though port was off	Continues to run while starting aid relay is off	Key switch is turned to OFF	Optional	1-5
		HIGH status was detected even though port was on				

No.	Fault (alarm) location	Fault/alarm condition	Engine status	Reset condition	Availability of detection features	No. of flashes/flashing pattern of engine failure lamp
9	Main relay	Power cannot be turned off even though main relay is off	Continues to run normally	Relay returns to normal. This fault will persist even if key switch is turned to OFF.	Default	1-6
10	Rack actuator relay	LOW status was detected even though port was off	Is shut down	Key switch is turned to OFF	Standard	1-7
		HIGH status was detected even though port was on				
11	Oil pressure switch	Oil pressure switch is not turned on while engine is stopped	Continues to run normally. (Other option can be selected).	Key switch is turned to OFF	Optional	2-1
12	Power supply voltage	An ECU supply voltage of under 10.0 V was detected	Continues to run normally	Voltage returns to normal	Standard	2-3
		An ECU supply voltage of over 16.0 V was detected				
13	ECU temperature (alarm)	ECU temperature is over 105 °C	Continues to run normally. (Other option can be selected).	Temperature returns to normal; under 100 °C (other optional setting is allowed)	Optional	2-5
14	Oil pressure	Oil pressure switch is not turned off while engine is running	Continues to run normally. (Other option can be selected).	Pressure returns to normal	Optional	3-1
15	Battery charge (alarm)	Battery charging switch is not turned off while engine is running	Continues to run normally	Key switch is turned to OFF	Optional	3-2
16	Battery charging switch	Battery charging switch is not turned off while engine is running	Continues to run normally	Key switch is turned to OFF	Optional	2-2
17	Coolant temperature (alarm)	Coolant temperature is over 110 °C	Continues to run normally. (Other option can be selected).	Temperature returns to normal; under 105 °C (other optional setting is allowed)	Standard	3-6

TROUBLESHOOTING

No.	Fault (alarm) location	Fault/alarm condition	Engine status	Reset condition	Availability of detection features	No. of flashes/flashing pattern of engine failure lamp
18	ECU-ROM	Flash ROM checksum error occurred	Is shut down	Key switch is turned to OFF	Standard	4-1
19	ECU-EEPROM	Reading/writing error occurred	Continues to run normally			
		Checksum error occurred				
21	ECU-sub CPU	Communication with sub microcomputer failed	Continues to run normally			
22	ECU-mapping format	Mapping format is invalid	Is shut down			
23	ECU-temperature sensor	Sensor voltage is over 4.6 V or under 1.0 V	Continues to run normally	Temperature returns to normal		

LONG-TERM STORAGE

This section of the Operation Manual describes the procedures necessary to place the engine into long-term storage (six months or longer) and how to place it back into operation.

BEFORE YOU PLACE THE ENGINE IN LONG-TERM STORAGE

DANGER

Explosion Hazard!



- Never short out the battery terminals, including when checking the remaining battery charge. This will result in a spark and may cause an explosion or fire. Use a hydrometer to check the remaining battery charge.
- If the electrolyte is frozen, slowly warm the battery before you recharge it.
- Failure to comply will result in death or serious injury.

WARNING

Burn Hazard!



- Batteries contain sulfuric acid. Never allow battery fluid to come in contact with clothing, skin or eyes. Severe burns could result. Always wear safety goggles and protective clothing when servicing the battery. If battery fluid contacts the eyes and/or skin, immediately flush the affected area with a large amount of clean water and obtain prompt medical treatment.
- Failure to comply could result in death or serious injury.

CAUTION

Flying Object Hazard!



- Always wear eye protection when servicing the engine and when using compressed air or high-pressure water. Dust, flying debris, compressed air, pressurized water or steam may injure your eyes.
- Failure to comply may result in minor or moderate injury.

NOTICE

Put a cover to protect the air cleaner, turbocharger (if equipped) and electric components from damage when you use steam or high-pressure water to clean the engine.

Perform the next Preventive Maintenance procedure. For example, if there are 10 hours remaining before the 250 hour maintenance, you should do the maintenance before you place the engine in storage.

See *Periodic Maintenance Schedule* on page 78.

1. Flush the radiator and refill with Long Life Engine Coolant. See *Engine Coolant Specifications* on page 63 for engine coolant specifications and See *Filling Radiator with Engine Coolant* on page 63 for the procedure for draining and refilling the cooling system.
2. Clean the exterior of the engine so it is free of grease and oil.
3. Drain the fuel tank or make sure it is completely full. See *Filling the Fuel Tank* on page 57.
4. Lubricate exposed parts of the engine speed control system.
5. Protect the air cleaner, muffler and electrical components (alternator, starter motor, switches, EGR valve, controller) from water and dust.
6. Disconnect the negative (-) battery cable to prevent the battery from discharging.
7. Check the battery fluid and add distilled water as required. See *Check battery and recharge* on page 84.
8. Charge the battery once a month during storage.
9. Rotate the engine without starting, every four to six months.

RETURNING THE ENGINE TO SERVICE

1. Perform the *Daily Checks on page 65*.
2. The engine should be pre-oiled before startup. Crank the engine, leaving the fuel system shut off so the engine will not start, for 15 seconds. Then pause for 30 seconds. Repeat the procedure until you have cranked the engine for a total of one minute. This will circulate the oil in the engine's lubrication system.
3. Prime the fuel system. See *Priming the Fuel System on page 58*.
4. Start the engine. Allow the engine to idle for approximately 15 minutes while you check for:
 - Proper oil pressure
 - Fuel, engine oil, or coolant leaks
 - Proper operation of the indicators and/or gauges.
5. Avoid prolonged operation at minimum or maximum engine speeds and loads for the remainder of the first hour of operation.

This Page Intentionally Left Blank

SPECIFICATIONS

GENERAL

■ Mechanical governor engine

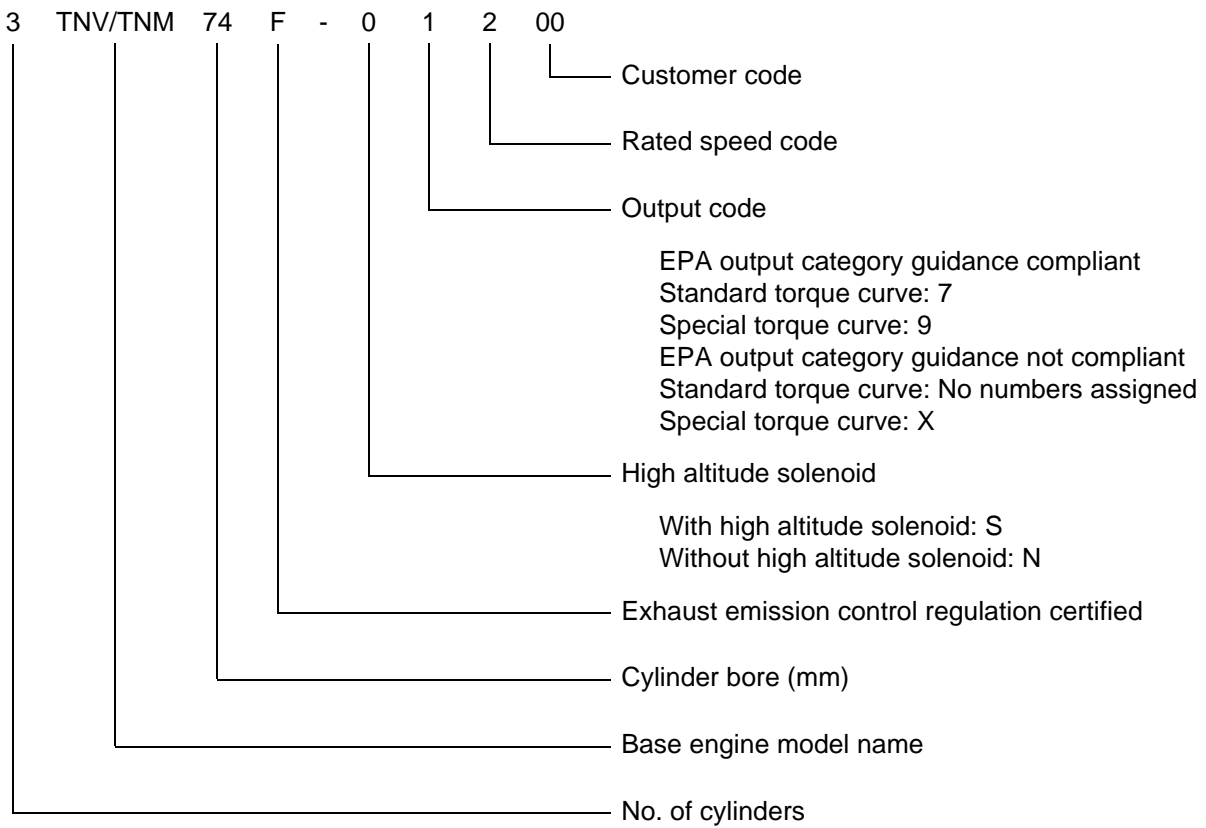

SPECIFICATIONS

■ Electronic governor engine

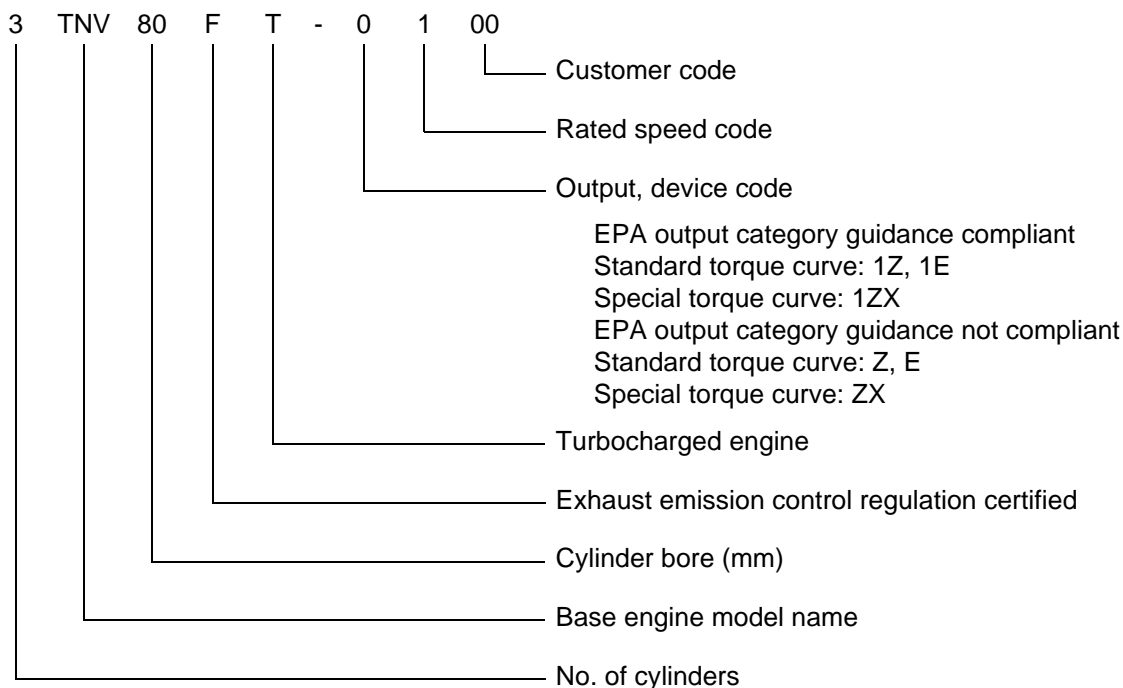

■ Engine general specifications

Type	Vertical in-line, water cooled, 4-cycle diesel engine	
Combustion system	Direct injection models	Direct injection
	Indirect injection models	Swirl chamber (ball-type)
Starting system	Electric starting	
Cooling system	Radiator	
Lubricating system	Forced lubrication with trochoid pump	
PTO position	Flywheel end	
Direction of rotation	Counterclockwise viewed from flywheel end	

Note:

- The information described in Principal Engine Specifications is for a “standard” engine. To obtain the information for the engine installed in your driven machine, please refer to the manual provided by the driven machine manufacturer.
- Engine rating conditions are as follows (SAE J1349, ISO 3046/1):
 - Atmospheric condition: Room temperature 25 °C (77 °F), atmospheric pressure 29.53 in. Hg (100 kPa, 750 mm Hg), relative humidity 30%
 - Fuel temperature at fuel injector pump Inlet: 40 °C (104 °F)
 - Fuel feeding pressure: 20 ± 10 kPa (net) after engine break-in has been performed with the cooling fan, air cleaner and muffler installed to the engine.
 - With cooling fan, air cleaner, muffler: YANMAR standard
 - After the engine break-in period. Output allowable deviation: ± 3%
 - 1 PS = 0.7355 kW
 - 1 hp SAE (Society of Automotive Engineers) = 0.7457 kW
 - Engine output when using JIS grade 2 diesel fuel
 - Engine rated power for North America
In order to comply with the EPA’s guidance on Power Category (CD-2022-09 (NRCI)), the rated power of some engines for North America from the 2025 model year and onwards (engines marked with ♦ in “Engine Specifications”) has been revised.

PRINCIPAL ENGINE SPECIFICATIONS

■ **3TNM74F**

Engine model		3TNM74F / ◆3TNM74F-S7, N7							
Version		CL	CH			VH			
Type		Vertical in-line 4-cycle diesel engine							
Combustion system		Ball-type swirl chamber (IDI)							
Aspiration		Naturally aspiration							
No. of cylinders		3							
Bore x stroke		mm	ø74 x 77						
Displacement		L	0.993						
Engine rotation speed		min ⁻¹	1500	1800	3000	3600	3200	3400	3600
Continuous rated output (Gross)		kW	6.6	7.9	13.6	15.9/ ◆15.7			
		PS	9.0	10.7	18.5	21.6/ ◆21.0			
Rated output (Gross)		kW	7.3	8.8	14.9	17.8/ ◆17.3	16.0	17.0	17.8/ ◆17.3
		PS	9.9	12.0	20.3	24.2/ ◆23.5	21.8	23.1	24.2/ ◆23.5
High idling		min ⁻¹	1600	1925	3175	3770	3415	3630	3840
Engine weight (dry)		kg	110				83		
Compression ratio		23.5							
PTO position		Flywheel end							
Direction of rotation		Counterclockwise viewed from flywheel end							
Speed governor		Mechanical, centrifugal type (all speed governor)							
Cooling system		Liquid-cooled with radiator							
Lubricating system		Forced lubrication with trochoid pump							
Normal oil pressure at rated engine speed		MPa	0.29		0.34				
Normal oil pressure at low idle speed		MPa	0.06		0.06				
Starting system		Electric starting (starter motor: DC12 V - 1.2 kW)							
Charging system		Alternator: 12 V, 40 A							
Recommended battery capacity		12 V 433CCA							
Starting aids		Glow plug (4 seconds)							
Dimensions (L x W x H)		mm	556 x 422 x 545		556 x 422 x 568		456 x 416 x 537		
Engine oil pan capacity		L	2.9 / 1.6 (Dipstick upper limit / lower limit)		3.4 / 1.8 (Dipstick upper limit / lower limit)		2.9 / 16 (Dipstick upper limit / lower limit)		
Engine coolant capacity		L	1.0 (Engine only)						
Standard cooling fan		mm	ø310 x 5 blade pusher-type *1				ø335 x 7 blade suction-type *1		
Crank V-pulley dia./ Fan V-pulley dia.		mm	ø100 / ø90 *1				ø110 / ø100 *1		
Top clearance		mm	0.708 ± 0.070 (consider oil clearance)						

*1: May vary depending on the driven machine.

◆: Engine complaint to EPA output category guidance (2025 model year and onwards)

SPECIFICATIONS

■ 3TNV74F

Engine model		3TNV74F		
Version		VM		
Type		Vertical in-line 4-cycle diesel engine		
Combustion system		Ball-type swirl chamber (IDI)		
Aspiration		Naturally aspiration		
No. of cylinders		3		
Bore x stroke	mm	ø74 x 77		
Displacement	L	0.993		
Engine rotation speed	min ⁻¹	2400	2500	3000
Continuous rated output	kW			
	PS			
Rated output (Gross)	kW	11.2	11.6	14.2
	PS	15.2	15.8	19.3
High idling	min ⁻¹	2595	2700	3210
Engine weight (dry)	kg	98 / 103		
Compression ratio		23.1		
PTO position		Flywheel end		
Direction of rotation		Counterclockwise viewed from flywheel end		
Speed governor		Mechanical, centrifugal type (all speed governor)		
Cooling system		Liquid-cooled with radiator		
Lubricating system		Forced lubrication with trochoid pump		
Normal oil pressure at rated engine speed	MPa	0.34		
Normal oil pressure at low idle speed	MPa	0.06		
Starting system		Electric starting (starter motor: DC12 V - 1.0 kW)		
Charging system		Alternator: 12 V, 40 A		
Recommended battery capacity		12 V 433CCA		
Starting aids		Glow plug (3 seconds)		
Dimensions (L x W x H)	mm	504 x 441 x 542		
Engine oil pan capacity	L	2.8 / 1.5 (Dipstick upper limit / lower limit)		
Engine coolant capacity	L	0.9 (Engine only)		
Standard cooling fan	mm	ø310 x 5 blade pusher-type *1		
Crank V-pulley dia./ Fan V-pulley dia.	mm	ø110 / ø100 *1		
Top clearance	mm	0.778 ± 0.069 (consider oil clearance)		

*1: May vary depending on the driven machine.

■ **3TNV76F**

Engine model		3TNV76F
Version		VM
Type		Vertical in-line 4-cycle diesel engine
Combustion system		Ball-type swirl chamber (IDI)
Aspiration		Naturally aspiration
No. of cylinders		3
Bore × stroke	mm	ø76 × 82
Displacement	L	1.116
Engine rotation speed	min ⁻¹	3000
Continuous rated output	kW	
	PS	
Rated output (Net)	kW	16.0
	PS	21.8
High idling	min ⁻¹	3235 ± 25
Engine weight (dry) with flywheel housing*1	kg	103
PTO position		Flywheel end
Direction of rotation		Counterclockwise viewed from flywheel end
Cooling system		Liquid-cooled with radiator
Lubricating system		Forced lubrication with trochoid pump
Normal oil pressure at rated engine speed	MPa	0.29 - 0.44
Normal oil pressure at low idle speed	MPa	0.06
Starting system		Electric starting (starter motor: DC12 V - 1.1 kW)*3
Charging system		Alternator: 12 V, 40 A*3
Recommended battery capacity		12 V, 36 Ah (5 h rating)*3
Dimensions (L × W × H)*1	mm	523 × 427 × 532
Engine oil pan capacity*2	L	3.4 / 1.8 (Dipstick upper limit / lower limit)
Engine coolant capacity	L	0.9 (Engine only)
Standard cooling fan	mm	ø335 × 6 blade pusher-type*3
Crank V-pulley dia./ Fan V-pulley dia.	mm	ø110 / ø100 *3
Top clearance	mm	0.819 ± 0.072

*1: Engine specifications without radiator.

*2: Engine oil capacity for a "Deep Standard" oil pan. Refer to the operation manual provided by the driven machine manufacturer for the actual engine oil capacity of your machine.

*3: May vary depending on application.

SPECIFICATIONS

■ 3TNV80F

Engine model	3TNV80F / ◆3TNV80F-S7, N7									
Version	CL	VM							VH	
Type	Vertical in-line 4-cycle diesel engine									
Combustion system	Ball-type swirl chamber (IDI)									
Aspiration	Naturally aspiration									
No. of cylinders	3									
Bore x stroke	mm	ø80 x 84								
Displacement	L	1.266								
Engine rotation speed	min ⁻¹	1500	1800	2200	2400	2500	2600	2800	3000	3200
Continuous rated output	kW	8.2	9.7							
	PS	11.2	13.2							
Rated output (Gross)	kW	9.5	10.7	13.4	14.6	15.2	15.8	17.0	17.8/ ◆17.3	17.8/ ◆17.3
	PS	12.9	14.6	18.2	19.9	20.7	21.5	23.1	24.2/ ◆23.5	24.2/ ◆23.5
High idling	min ⁻¹	1600	1925	2380	2595	2700	2815	3020	3235	3415
Engine weight (dry)	kg	130		99 / 117						
Compression ratio	23.1									
PTO position	Flywheel end									
Direction of rotation	Counterclockwise viewed from flywheel end									
Speed governor	Mechanical, centrifugal type (all speed governor)									
Cooling system	Liquid-cooled with radiator									
Lubricating system	Forced lubrication with trochoid pump									
Normal oil pressure at rated engine speed	MPa	0.34								
Normal oil pressure at low idle speed	MPa	0.06								
Starting system	Electric starting (starter motor: DC12 V - 1.1 kW)									
Charging system	Alternator: 12 V, 40 A									
Recommended battery capacity	12 V 433CCA									
Starting aids	Glow plug (3 or 4 seconds)									
Dimensions (L x W x H)	mm	567 x 427 x 532		523 x 427 x 532						
Engine oil pan capacity	L	3.4 / 1.8 (Dipstick upper limit / lower limit)								
Engine coolant capacity	L	0.9 (Engine only)								
Standard cooling fan	mm	ø335 x 6 blade pusher-type *1								
Crank V-pulley dia./ Fan V-pulley dia.	mm	ø110 / ø100 *1								
Top clearance	mm	0.778 ± 0.069 (consider oil clearance)								

*1: May vary depending on the driven machine.

◆: Engine complaint to EPA output category guidance (2025 model year and onwards)

■ **3TNV80FT**

Engine model		3TNV80FT / ◆3TNV80FT-1Z
Version		VM
Type		Vertical in-line 4-cycle diesel engine
Combustion system		Ball-type swirl chamber (IDI)
Aspiration		Equipped with a turbocharger
No. of cylinders		3
Bore × stroke	mm	ø80 × 84
Displacement	L	1.266
Engine rotation speed	min ⁻¹	2600
Continuous rated output	kW	
	PS	
Rated output (Gross)	kW	18.4 / ◆17.3
	PS	25.0 / ◆23.5
High idling	min ⁻¹	2815
Engine weight (dry)	kg	117
Compression ratio		23.0
PTO position		Flywheel end
Direction of rotation		Counterclockwise viewed from flywheel end
Speed governor		Electronic governor (all-speed governor)
Cooling system		Liquid-cooled with radiator
Lubricating system		Forced lubrication with trochoid pump
Normal oil pressure at rated engine speed	MPa	0.34
Normal oil pressure at low idle speed	MPa	0.06
Starting system		Electric starting (starter motor: DC12 V - 1.1 kW)
Charging system		Alternator: 12 V, 40 A
Recommended battery capacity		12 V 433CCA
Starting aids		Glow plug (3 or 4 seconds)
Dimensions (L × W × H)	mm	523 × 427 × 532
Engine oil pan capacity	L	3.4 / 1.8 (Dipstick upper limit / lower limit)
Engine coolant capacity	L	0.9 (Engine only)
Standard cooling fan	mm	ø335 × 6 blade pusher-type *1
Crank V-pulley dia./ Fan V-pulley dia.	mm	ø110 / ø100 *1
Top clearance	mm	0.72 ± 0.06

*1: May vary depending on the driven machine.

◆: Engine complaint to EPA output category guidance (2025 model year and onwards)

SPECIFICATIONS

■ 3TNV88F

Engine model		3TNV88F-U		3TNV88F-E / ◆3TNV88F-1E		
Version		CL		VM		
Type		Vertical in-line 4-cycle diesel engine				
Combustion system		Direct injection (DI)				
Aspiration		Naturally aspiration				
No. of cylinders		3				
Bore x stroke	mm	ø88 x 90				
Displacement	L	1.642				
Engine rotation speed	min ⁻¹	1500	1800	2200	2300	2400
Continuous rated output	kW	13.0	14.3			
	PS	17.7	19.4			
Output (Gross)	kW	14.3	15.7	18.2 / ◆17.3		
	PS	19.4	21.3	24.7 / ◆23.5		
High idling	min ⁻¹	1600	1915	2350	2450	2550
Engine weight (dry)	kg	158		148 / 155		
Compression ratio		19.1				
PTO position		Flywheel end				
Direction of rotation		Counterclockwise viewed from flywheel end				
Speed governor		Mechanical governor (all-speed governor)		Electronic governor (all-speed governor)		
Cooling system		Liquid-cooled with radiator				
Lubricating system		Forced lubrication with trochoid pump				
Normal oil pressure at rated engine speed	MPa	0.294		0.360		
Normal oil pressure at low idle speed	MPa	0.059		0.06		
Starting system		Electric starting (starter motor: DC12 V - 1.7 kW)				
Charging system		Alternator: 12 V, 40 A				
Recommended battery capacity		12 V 413CCA				
Starting aids		Glow plug (15 seconds)				
Dimensions (L x W x H)	mm	608 x 532 x 709		600 x 577 x 694		
Engine oil pan capacity	L	6.7 / 3.9 (Dipstick upper limit / lower limit)				
Engine coolant capacity	L	2.0 (Engine only)				
Standard cooling fan	mm	ø360 x 6 blade pusher-type *1		ø335 x 6 blade suction-type *1		
Crank V-pulley dia./ Fan V-pulley dia.	mm	ø120 / ø90 *1		ø110 / ø110 *1		
Top clearance	mm	0.73 ± 0.06 (consider oil clearance)				

*1: May vary depending on the driven machine.

◆: Engine complaint to EPA output category guidance (2025 model year and onwards)

YANMAR

Head Office:
YANMAR POWER TECHNOLOGY CO., LTD.
1-32 Chayamachi, Kita-ku, Osaka, Japan
<https://www.yanmar.com>

Yanmar America Corporation
101 International Parkway
Adairsville, GA 30103, U.S.A.
TEL: +1-770-877-9894 FAX: +1-770-877-9009
<https://www.yanmar.com/us/>

Yanmar Europe B.V.
Brugplein11, 1332 BS Almere -de Vaart
The Netherlands.
TEL: +31-36-5493200 FAX: +31-36-5493209
<https://www.yanmar.com/eu/>

Yanmar Asia (Singapore) Corporation Pte Ltd.
4 Tuas Lane, Singapore 638613
TEL: +65-6861-3855 FAX: +65-6862-5189
<https://www.yanmar.com/sg/>

Yanmar Engine (Shanghai) Corporation Ltd.
Room 1101-1106, No.757 Mengzi Road,
Huangpu District, Shanghai 200023 PRC
TEL: +86-21-2312-0688 FAX: +86-21-6880-8090
<http://www.yanmar-china.com/cn/>

Yanmar South America Industria De Maquinas Ltda.
Av. Presidente Vargas 1400, Indaiatuba, S.P., Brazil, CEP: 13338-901
TEL: +55-19-3801-9224 FAX: +55-19-3875-3899, 2241
<https://www.yanmar.com/br/>

As of April 1, 2020

OPERATION MANUAL

3TNV74F, 3TNV76F, 3TNV80F,
3TNV80FT, 3TNV88F, 3TNM74F

1st edition: March 2012
11th edition: August 2022
11th edition 1st rev.: October 2022
12th edition: October 2024
13th edition: August 2025

Issued by: YANMAR POWER TECHNOLOGY CO., LTD.
Edited by: YANMAR GLOBAL CS CO., LTD.



YANMAR POWER TECHNOLOGY CO., LTD.

<https://www.yanmar.com>

0ATN4-EN002C
Aug.2025-0
PRINTED IN JAPAN